



SW Series Directions for Convert from the Surface Mounted Roller Plate System to the 2893 Elevated Roller Plate System (PT SP30)

This conversion eliminates the #2 and #3 guide springs. Only the #1 Guide Spring is used on the SW Series machines.

A template is required for drilling the 3/8" hole for the Singles Roller Plate. See following instructions:

Fitting of the Roller Plate System

IMPORTANT: NEVER STAND IN FRONT OF A TRAP MACHINE, THE TRAP MACHINE MUST BE TURNED OFF AND THE SPRING RELEASED BEFORE ENTERING THE TRAP HOUSE. NEVER ATTEMPT TO MAKE ANY ADJUSTMENT WHEN THE THROW ARM IS IN THE COCKED POSITION.

1. The template must be used for drilling the singles' roller plate hole, for the purpose of centering the hole further away from the clay targets.
2. Remove the existing roller plate system from your machine.
3. Remove the #2 and #3 Guide Spring.
4. Place the template into position, as shown on Diagram C13, and align the 3/8" template hole with the 1/4" roller plate hole.
5. Clamp the template to the Top plate: use a "C" clamp.
6. Keep your drill perpendicular to the template and drill out the hole.
7. Remove the template.
8. The #3 guide spring is no longer used.
9. The template needs to be returned to Pat-Trap, Inc. Thank you.

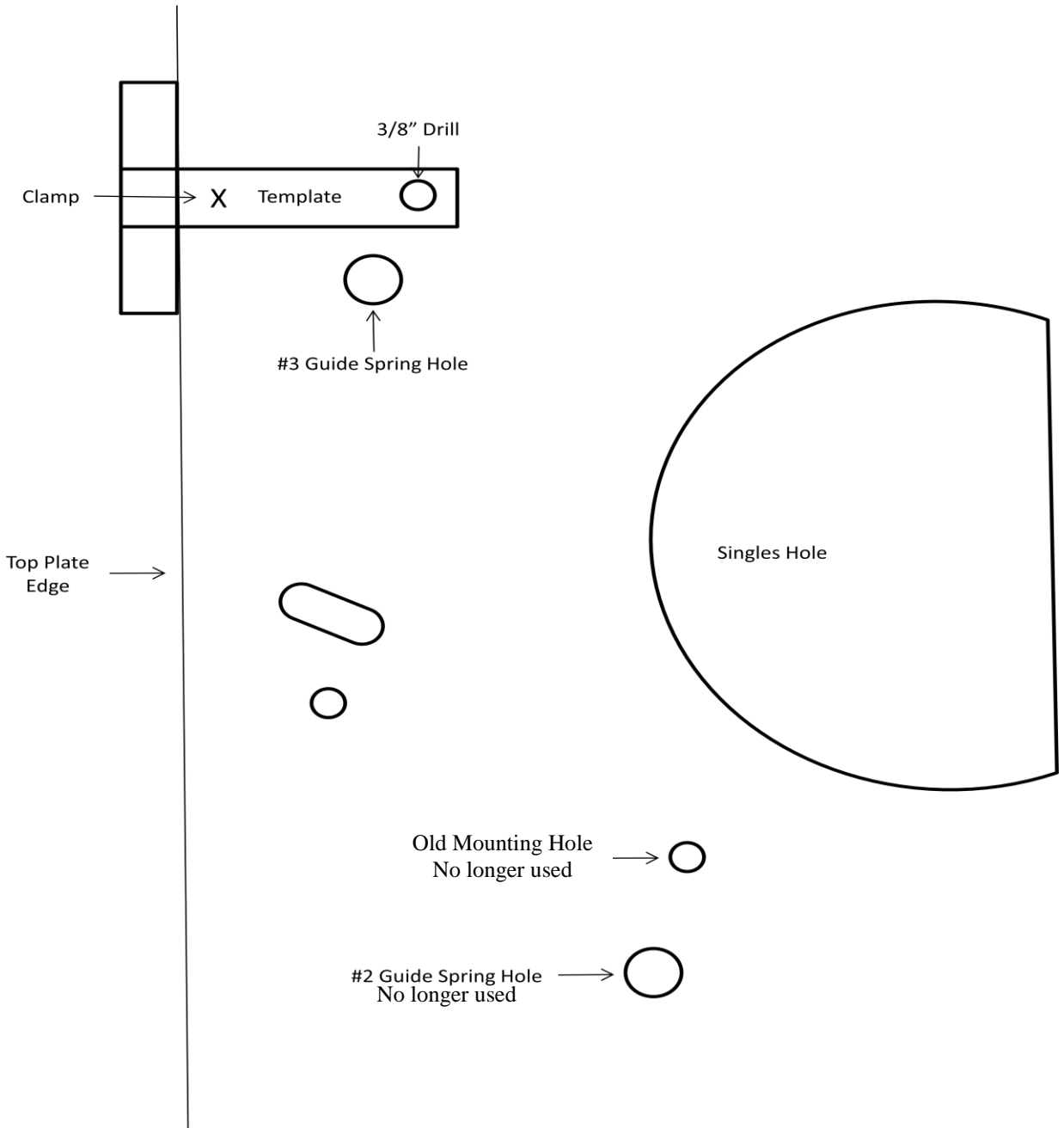

SW Series

Directions for converting from the Original Surface Mounted Roller Plates to the 2893 Elevated Roller Plate System (Part # SP30).

A template is required for drilling the 3/8" hole for the Singles' Roller Plate. See accompanying directions.

The Doubles Roller Plate holes are relocated as shown in the diagram.



This conversion eliminates the #2 and #3 Guide Springs. Only the #1 Guide Spring is used in SW Series machines.

The Doubles Roller Plate holes are relocated as shown on the following diagram.

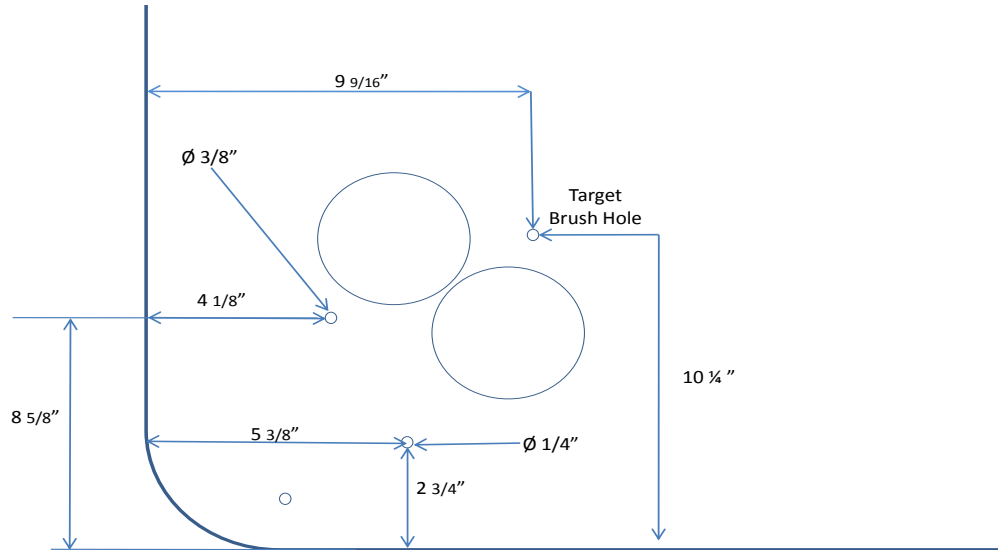

SW Series Pat-Trap Top Plate:
Relocated holes for the "2893 Elevated Singles/Doubles Roller Plate System".
This eliminates the #2 & #3 Guide Springs.

Not to scale for reference only



INSTALLATION AND POSITION OF THE ELEVATED ROLLER PLATE SYSTEM

Tools required for installation:

- | | |
|-------------------------------|----------------------|
| 1. Pilot Drill | 6. Small Pipe Wrench |
| 2. 1/4" drill | 7. Tape Measure |
| 3. 3/8" drill | 8. Tri-square |
| 4. 2 - 9/16" wrench | 9. Prick Punch |
| 5. Adjustable crescent wrench | 10. File |

Locate the new holes according to the following diagrams. Mark new hole locations with prick punch. Proceed to drill using appropriate sized drill for corresponding hole. File off any burrs. Then install roller plates as follows:

ROLLER PLATE ASSEMBLY AND POSITION

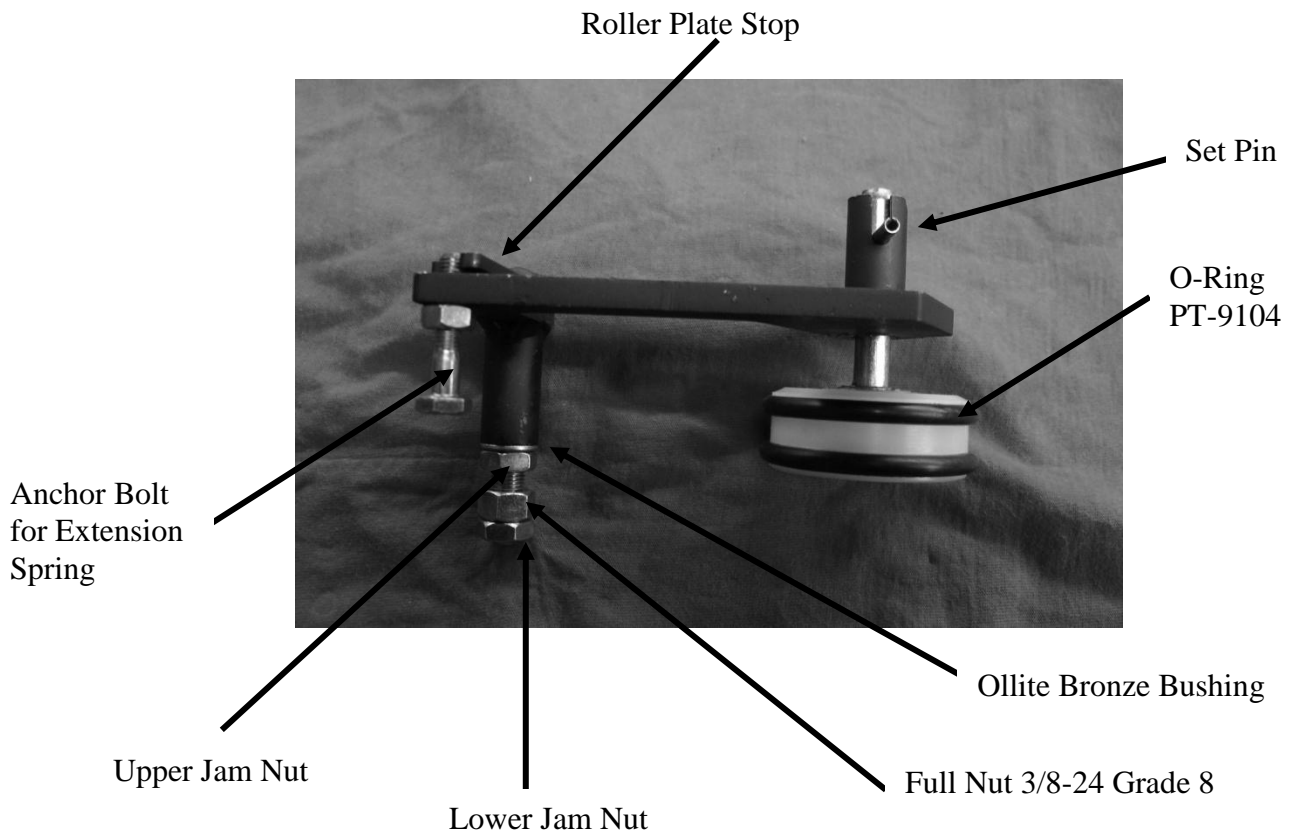



To set the position of the roller plate stop:

1. Adjust upper jam nut so that when the nut is tightened the roller plate will pivot freely: with no more than 1/32" of up/down play between the roller plate shaft and jam nut.
2. Use an adjustable wrench to turn the roller plate stop to the correct position,
3. Hold back on the roller plate stop with the adjustable wrench while tightening the Full nut. Torque nut to 35/40 ft/lbs.
4. Tighten jam nut against full nut while holding back against the roller plate stop with the adjustable wrench. Torque jam nut to approximately 15 ft/lbs.
5. Check for free pivot of the roller plate after tightening.
6. Reconnect the extension spring.
7. Check the measurement to each roller plate from the king pin.

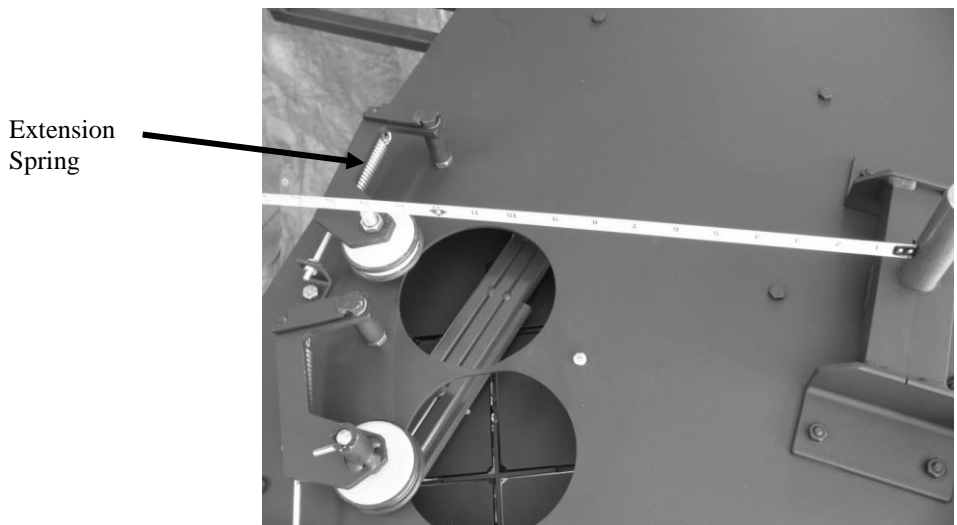

Extension Spring

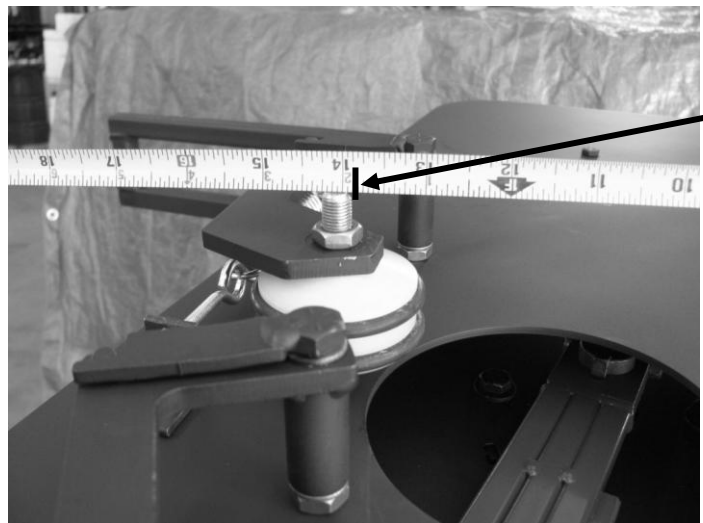

13 7/8"

Singles Roller Plate measurement is 13 7/8" from face of Kingpin Shaft to inside face of the Single Roller Wheel bolt.



PAT-TRAP, Inc.

Choice of the ATA

632 Western Avenue • Henniker, New Hampshire 03242 • Tel. (603) 428-3396 • Fax (603) 428-7340

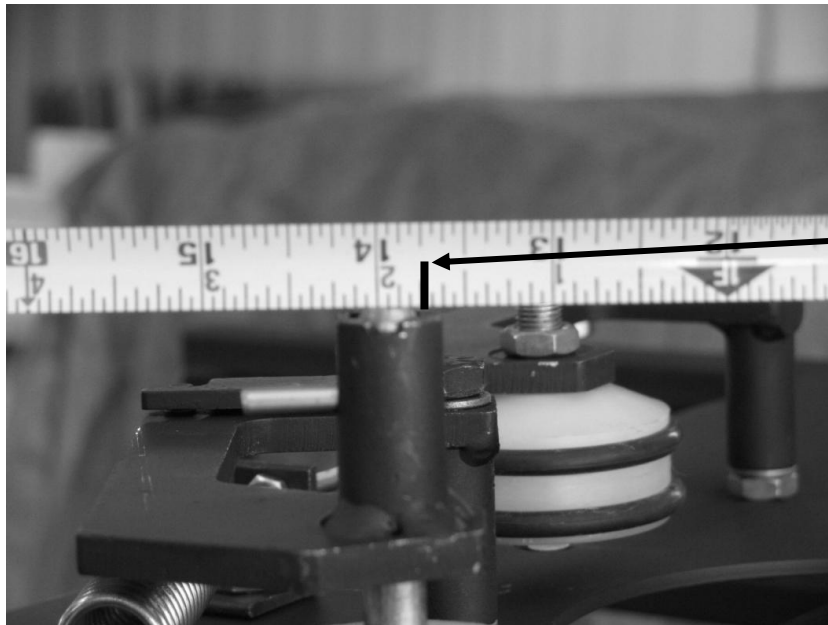
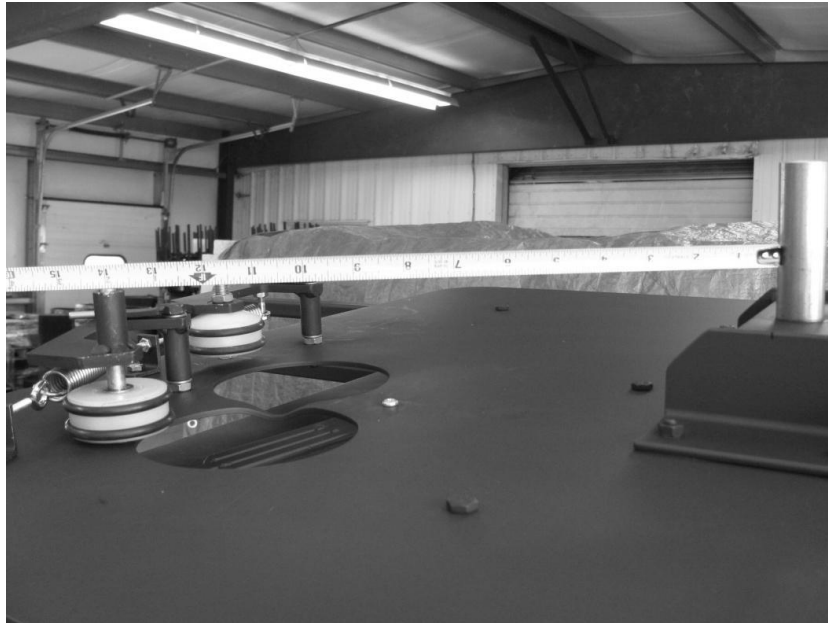

Doubles Roller Plate measurement is 13 ³/₄” from the face of the Kingpin Shaft to the inside face of the Doubles Roller Wheel bolt.



SETTING THE PROPER HEIGHT AND CANT OF THE ROLLER PLATES

Measure 1 7/8" to top of the roller plate surface.

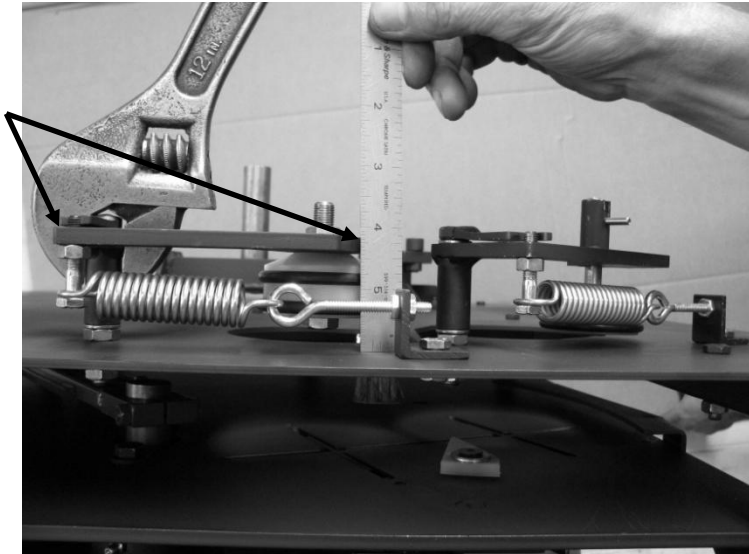

Adjusting height of Single Roller Plate

Use the Adjustable wrench to set the correct height of the Singles Roller Plate.

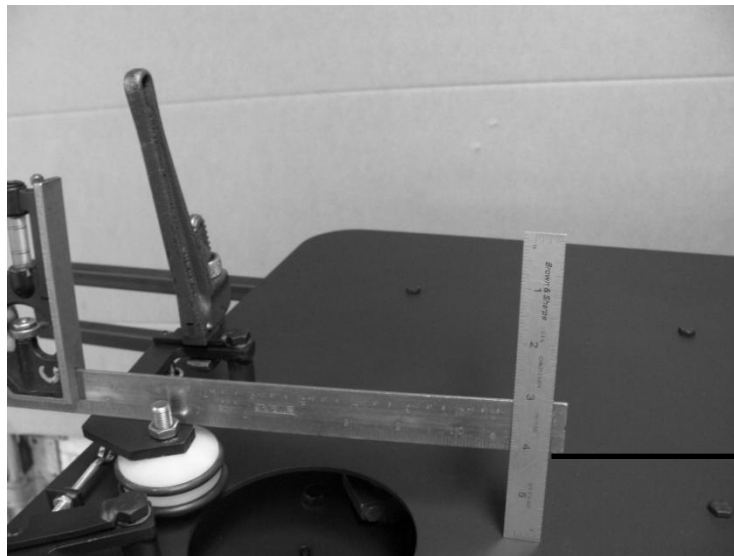

Setting Cant of Single Roller Plate

Use the Pipe Wrench to carefully tilt the roller plate to proper cant measurement. Recheck the measurement from the king pin to the roller plate.



Measure 1 13/16”
to top of the roller
plate surface.

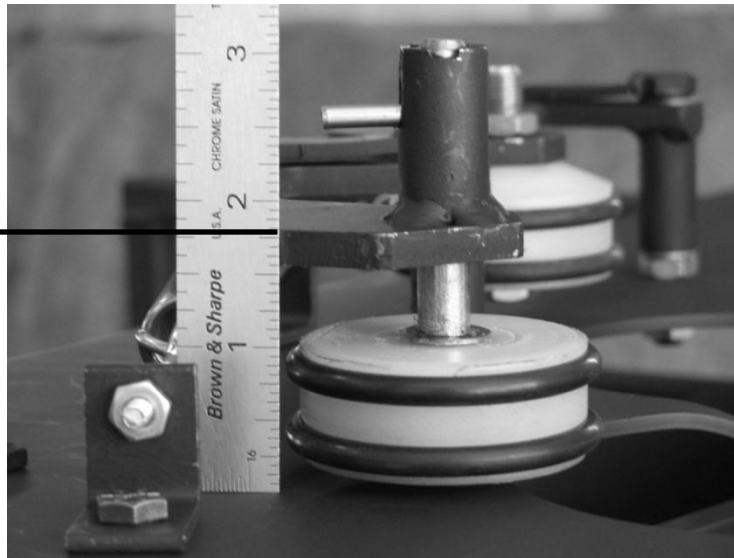

Adjusting height of Doubles Roller Plate

Use the Adjustable wrench to set the correct height of the **Doubles Roller Plate**.

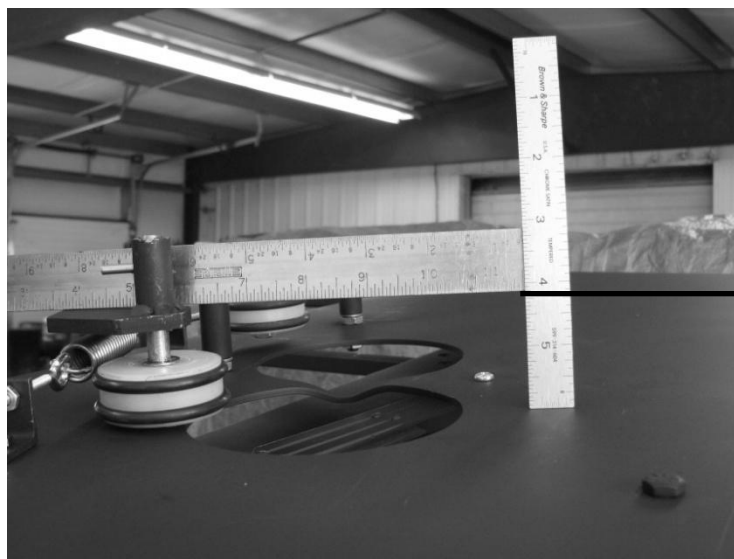

Setting Cant of Doubles Roller Plate

Use a Pipe Wrench to carefully tilt the roller plate to proper cant measurement. Recheck the measurement from the king pin to the roller plate.



ROLLER PLATE EXTENSION SPRING TENSION



Measuring 1/4" Long Tail on Eye Bolt for Proper Extension Spring Tension

The Roller Plate Assemblies are spring loaded to hold the targets in the PAT-TRAP[®] Turret. By adjusting the #10-32 Nuts on the eyebolt assembly, the proper tensioning of the extension springs is achieved. An exposed 1/4" long tail on the eyebolt is sufficient to properly secure the targets as shown in Diagram 3.37 above.

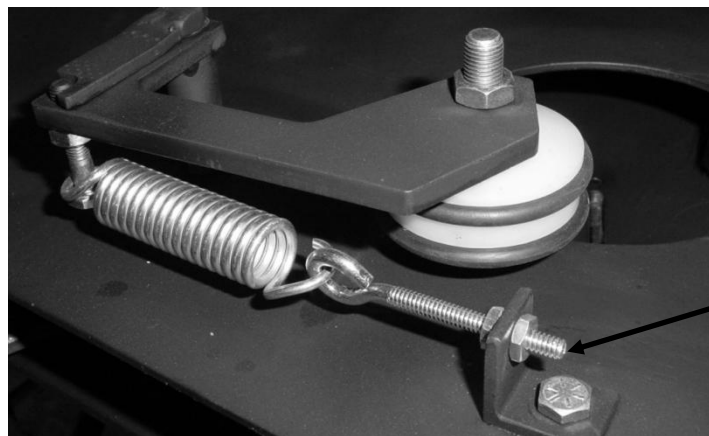

1/4" Long Tail on Eye Bolt for Proper Extension Spring Tension