

**INSTALLATION - SAFETY - MAINTENANCE**

# **MANUAL**

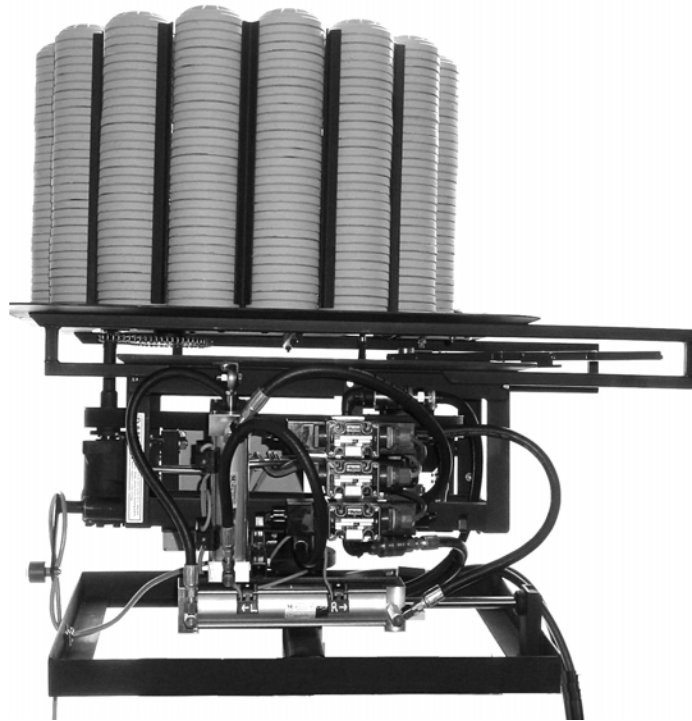

# **Pat-Trap<sup>®</sup>**

**Singles to Doubles In Seconds**

Serial #: \_\_\_\_\_

Date: \_\_\_\_\_



## WARNING

This Manual disclose details of a patented apparatus or device for throwing clay targets. The apparatus is clearly disclosed and claimed on our **U.S. Patent No. 5249563 and 6176229**. It is unlawful under United States Patent Law to practice, i.e. to make, use or sell a patented invention without the express permission of the owner/inventor thereof. Permission is expressly granted, **only to use**, the patented apparatus. The unauthorized making, using or selling of the patented apparatus constitutes patent infringement. It is the intent of the owner/inventor to prosecute infringers of the Patent to the full extent of the all applicable laws.



# **Table of Contents**

**Pat-Trap® Safety ..... 1**

**Trap House Specifications ..... 2**

**Installation of Pat-Trap machine and Hydraulic Pump..... 4**

**Serial # Location ..... 5**

**Pat-Trap Machine Weight and Dimensions..... 5**

**Removal/Replacement of Turret ..... 6**

**Mounting the Power Control Box..... 6**

**Connecting the Trap to the Power Source ..... 7**

**How the Pat-Trap® works ..... 8**

**Pat-Trap Switch Identification ..... 10**

**Turning the Pat-Trap® On & Off ..... 10**

**Loading the Pat-Trap® ..... 11**

**Pat-Trap® Singles Height ..... 13**

**Pat-Trap® Doubles Height..... 14**

**Adjustment for Pat-Trap® Doubles..... 15**

**Pat-Trap® Wobble Settings ..... 16**

**Change over to Wobble Setting ..... 17**

**Setting a Target Distance/Speed ..... 18**

**Setting Minimum Target Distance..... 19**

**Adjustment Height of Targets..... 21**

**Angle Adjustments ..... 22**

**Position of the Roller Plates ..... 24**



# **Table of Contents Cont.**

<b>Target Brush Maintenance.....</b>	<b>27</b>
<b>Cold Weather Adjustment, Temperature Release Time Stopping the Throw Arm on the Brake.....</b>	<b>28</b>
<b>Adjusting Release Time – Correction of Cycling Problem .....</b>	<b>29</b>
<b>Assembly and Maintenance of the Throw Arm Brake .....</b>	<b>30</b>
<b>Removal of Throw Arm .....</b>	<b>31</b>
<b>Disconnecting the Uni-Band (Main Spring) from the Clutch .....</b>	<b>32</b>
<b>Installation of the Throw Arm .....</b>	<b>32</b>
<b>Maintenance of the Cocking Pin .....</b>	<b>34</b>
<b>Installation of the “XXX”Doubles Finger &amp; Singles Finger .....</b>	<b>35</b>
<b>Replacement/Removal of Main shaft Clutch Assembly .....</b>	<b>37</b>
<b>Changing a Pair of Uni-Bands on a Main Shaft Clutch System .....</b>	<b>41</b>
<b>Assembly/Installation of the Uni-Band (Main Spring) to the Main Shaft Clutch.....</b>	<b>43</b>
<b>Replacement of the Elevator Extension Spring .....</b>	<b>46</b>
<b>Replacement of the Elevator Compression Spring .....</b>	<b>47</b>
<b>Throw Arm Shaft Bearing Maintenance .....</b>	<b>48</b>
<b>Hydraulic Valve Identification – Standard Trap .....</b>	<b>49</b>
<b>Hydraulic Valve Identification- Wobble Trap .....</b>	<b>50</b>
<b>Soft Shift Valve Wiring Guide (Oscillation/Wobble) .....</b>	<b>51</b>
<b>Single Solenoid Valve (Throw Arm/Turret) Wiring Guide .....</b>	<b>52</b>
<b>Replacement of a Hydraulic Valve .....</b>	<b>53</b>
<b>Replace a Field Angle Limit Switch .....</b>	<b>54</b>



# **Table of Contents Cont.**

**Wiring Guide for Field Angle Limit Switches (#11 (A)&#12(A)) ..... 55**

**Wobble Wiring Guide for Up and Down Limit Switches (#11A & #12A) .. 56**

**Replacement of Oscillation Cylinder ..... 58**

**Replacement of Wobble Cylinder ..... 60**

**General Maintenance ..... Appendix I**

**Procedure to Flush Hydraulic Oil ..... Appendix II**

**Timing of the Pinion..... Appendix III**

**Assembly of the Pinion and Sprocket.....Appendix IV**

**“G” Series Trap and Wobble Trap Machine Power Control Box..... V**

**Drying Out a Pat-Trap after a flood.....Appendix VI**

**Trouble Shooting.....Appendix VII**

**“G” Series Solid State Wiring Diagram .....Appendix VIII**

**Fasteners, Hardware and Fuses ..... Appendix IX**



**PAT-TRAP, Inc.**

**\*Choice of the ATA\***

632 Western Avenue • Henniker, New Hampshire 03242 • Tel. (603) 428-3396 • Fax (603) 428-7340



## The PAT-TRAP®

NEVER STAND IN FRONT OF A TRAP MACHINE. THE TRAP MACHINE MUST BE TURNED OFF AND THE SPRING RELEASED BEFORE ENTERING THE TRAP HOUSE. NEVER ATTEMPT TO MAKE ANY ADJUSTMENT WHILE THE THROW ARM IS COCKED.

### **DO NOT TOUCH! -- ASK FOR HELP**

NEVER ATTEMPT TO LOAD THE TRAP WHEN IT IS COCKED. ALWAYS RELEASE THE TARGET FROM THE TRAP MACHINE.

NEVER ADVANCE THE THROW ARM BY HAND WHEN THE ON/OFF/RELEASE SWITCH IS IN THE ON POSITION. THIS MAY DAMAGE THE MACHINE.

The target throw arm extends 4" beyond the throw plate. Keep away from moving parts. Never stand in front of the trap machine.

When the machine is turned ON the throw arm will travel forward to the cocked position through the danger zone.

When the throw arm is fired, the arm will travel through the indicated danger area zone.

The throw arm can be fired by pushing the pullcord button. It can also be fired by hand; by pushing the arm forward off the brake when the machine is either On or Off.

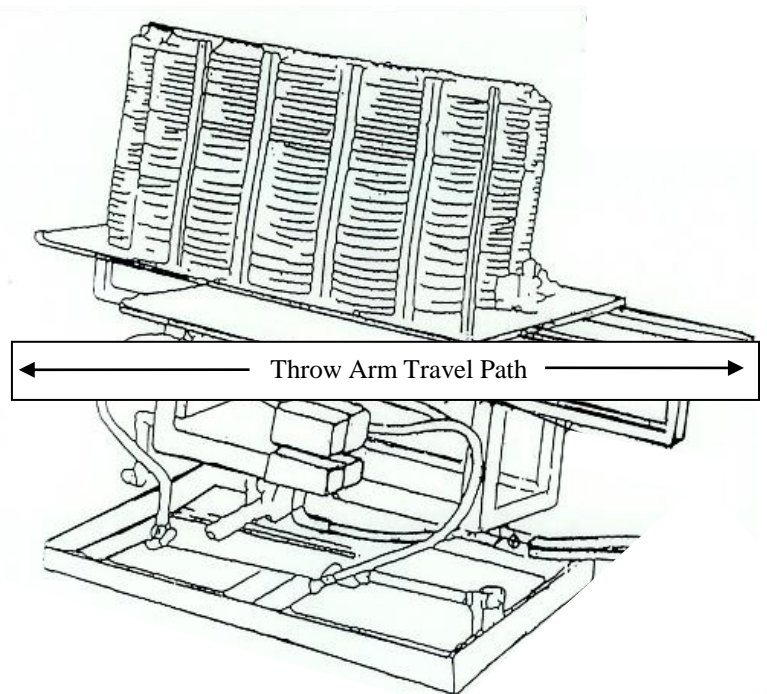



**Top-Down Suggested Plan View of Trap House**

1. Water proof all sides below 4" grade.
2. Open front trap houses are preferred if grade allows it.
3. All Walls and Roof are shown as 4" thickness.
4. Reinforce concrete per local building codes.
5. Install drainage as required.
6. Trap House Door should be weather proof and can be locked.
7. Trap House length in not less than 7'6" or more than 9'6" per ATA.
8. Trap House width is not less than 7'6" or more than 9'6" per ATA.

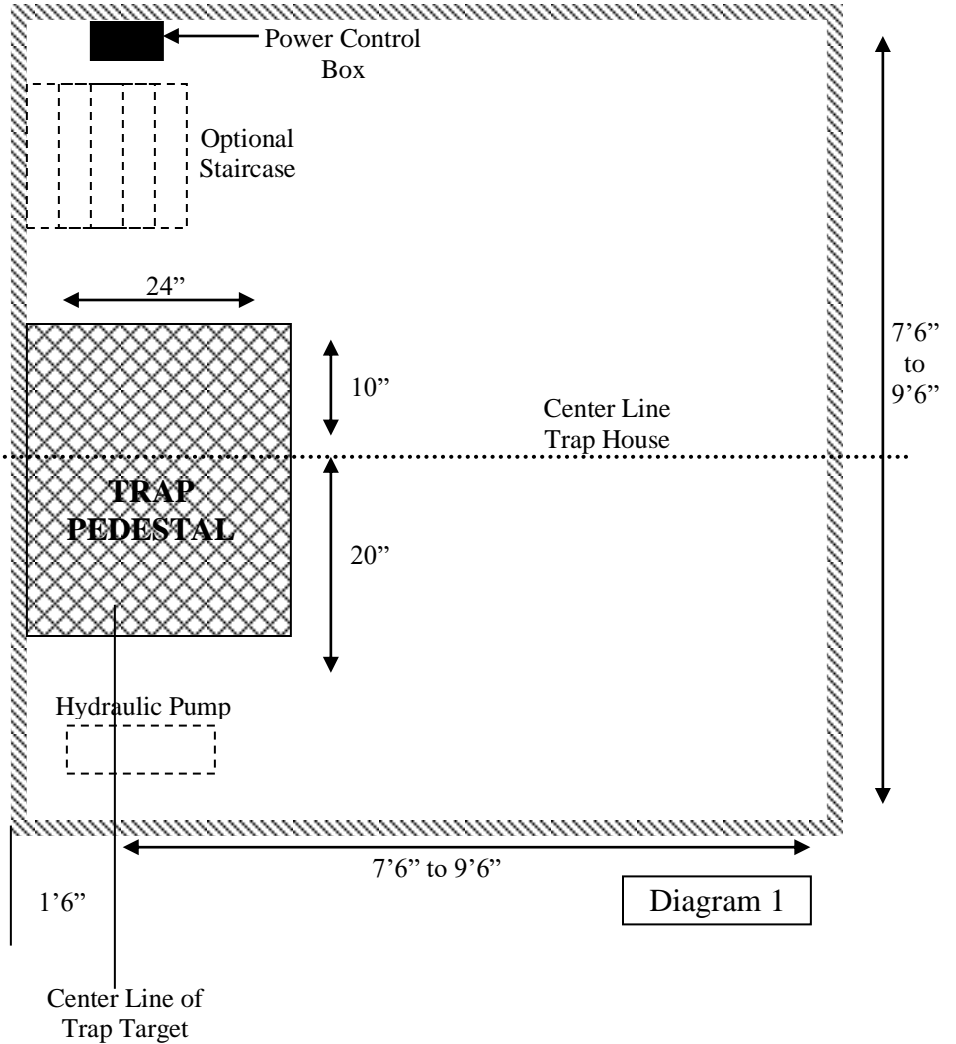





**Side View (Cross Section) of Trap House**

1. Paint Roof and Rear Wall Green.
2. Water Proof All Sides Below Grade.
3. Open Front Trap Houses are preferred if grade permits. Trap house opening is a minimum of 26" to a maximum of 43". Wall minimum of 0" from top of pedestal to a maximum of 16" from top of pedestal.
4. All Walls and Roof are shown as 4" Thick.
5. Reinforce Concrete Per Local Building Codes.
6. Install Drainage as Required.
7. Trap House Door Should be Weather Proof and Capable of Being Locked.
8. Trap House Length is Not Less Than 7'6" or More Than 9'6"
9. Trap House Height is 2'2" Minimum and 3'0" Maximum from Shooting Station #3.

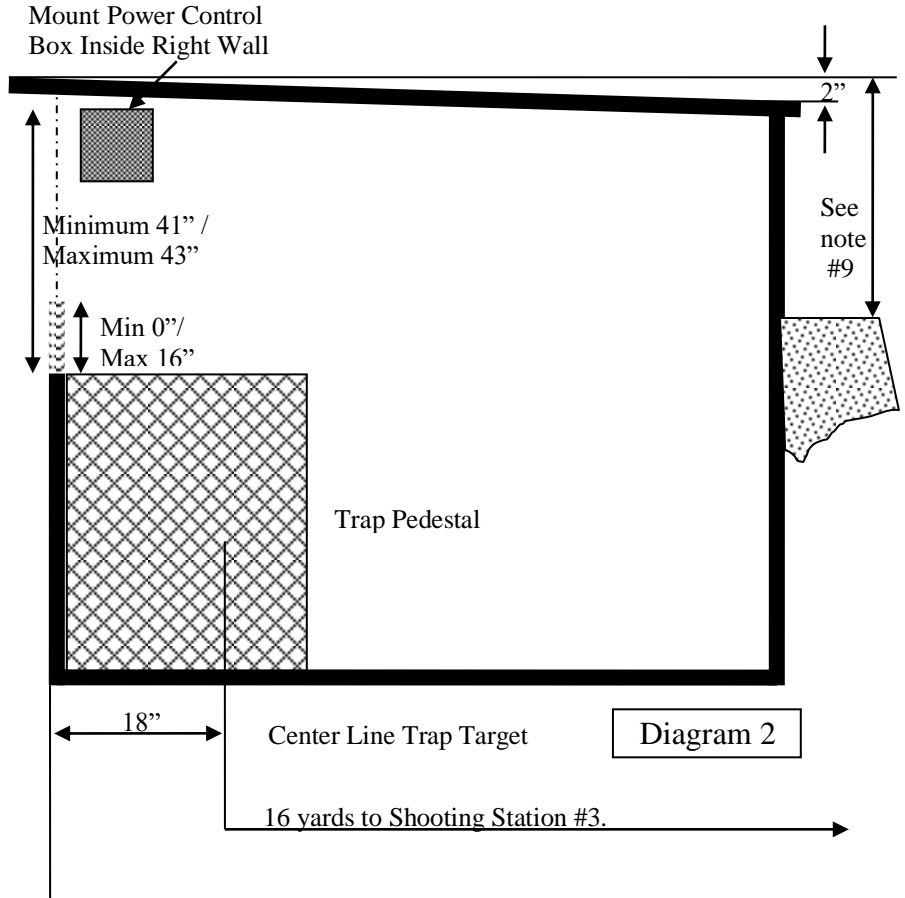

For Complete Rules: See Amateur Trapshooting Association Official Rules Section XIII Standards for Trap Houses, Targets, Target Settings, Guns and Ammunition.



## Installation of the Trap Machine and Hydraulic Pump

1. Place the trap machine in the trap house with the front of the machine as close as possible to the front wall. The platform which the trap sits on *must be level*. See Diagram 2. If necessary, the turret may be removed from the machine to place the trap into the house. Please refer to page 6 for instructions.
2. The trap is to be set *off center* of the trap house. See Diagram 1.

Measure and mark the center of the trap house. The front of the base is marked with a notch at 10” in from the left – facing the front of the machine. Set the machine so that this notch is now at the center of the trap house. The base of the trap machine should be set at 41” minimum from the ceiling; however, a setting of approximately 43” is best for loading targets.

3. Holes are provided in the corners of the base to screw down/secure your machine.
4. Place the pump on a raised platform (ie: a cinder block and you may place a foam or rubber pad underneath to reduce vibration is desired) on the left side of the trap house. See Diagram 1. If flooding is a problem in your area then mount the pump on a platform that is above the water line. The pump reservoir is filled at the factory with **5W-20** oil. (0W-20 can be used for colder temperatures.)



**Hydraulic Pump System**

**Diagram 3**

5. If not already connected, connect the quick release fittings from the pump hydraulic hoses to the hoses at the rear of the trap machine; slide back the outer sleeve of the female fitting while pushing on to the male fitting. Allow the female sleeve to slide forward to lock. Gently tug on the connections to check that they are securely fastened.



**PAT-TRAP® SERIAL NUMBER LOCATION**

A fully crated Pat-Trap is 420 #.  
 Machine and pump weighs 350 #.  
 Turret weigh 50 #.  
 Pump weight 50 #.  
 Pat-Trap machine w/o pump and  
 turret weight 250 #.

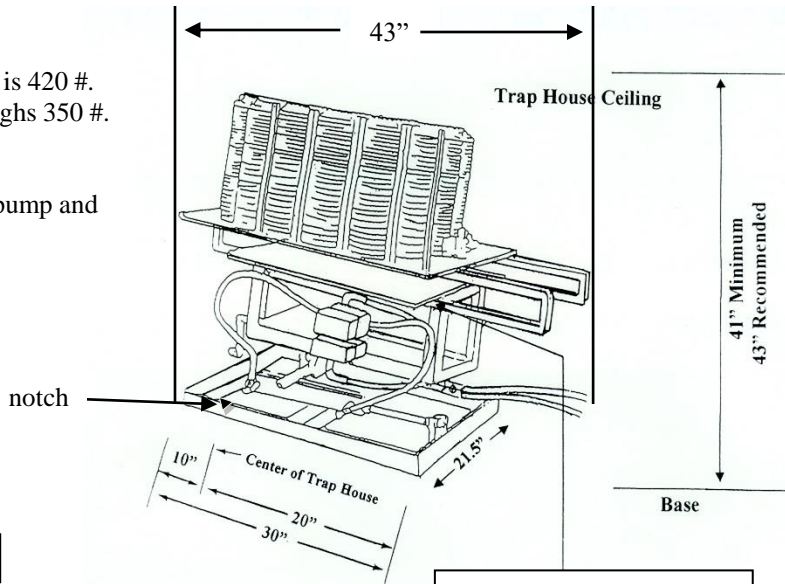

Diagram 4

The Serial Number is stamped on the edge of the 1/4" steel plate.

**Measurements of the Pat-Trap machine**

From the bottom of the base to the top of the King Pin 24"

From the bottom of the base to the top of the turret 34 3/4"

Trap cog top max – 39 1/2"  
 Trap cog bottom min – 37"

Wobble base to throw plate (up/down angles) min 17 3/4"

Wobble base to throw plate (up/down angles) max 24 1/2"

Wobble max – 39 1/2"  
 Wobble Min – 34 3/4"

**Base Dimensions of PAT-TRAP®**



Serial Number is stamped here.  
 Example: "G4190"  
 Also located on pump.

Diagram 5

**PAT-TRAP® Serial Number Location**

Serial Number Location: The Serial Number is stamped on the front left edge (shooting stand 1 Side) of the 1/4" thick steel "Throw Plate".



## REMOVAL/REPLACEMENT OF THE TURRET

**WARNING:** To prevent damage to your machine the turret must be replaced the same way as it was removed.

1. Observe how the cogs are meshed with the cam followers: i.e., the pair of cam followers has to mesh within the cogs located beneath the turret.
2. To remove the turret, have two people, one on each side of the trap machine, lift straight up (no tools are required). Both people must lift up evenly to prevent the turret from binding on the kingpin. Replace the turret in the same way that it was removed.

## MOUNTING THE POWER CONTROL BOX

1. Mount the power control box just inside the trap house on the right wall near the ceiling of the trap house (See Diagrams 1). This should be the side of the trap where personnel enter/exit the trap house. The power control box should be easily accessible so that it can be operated by placing your hand around the corner of the wall and not exposing your body to the front of the trap machine. The power control box will also be accessible to trap personnel when setting the machine for Doubles. Proper location of the control box is important to insure safety.

**NEVER STAND IN FRONT OF A TRAP MACHINE. THE TRAP MACHINE MUST BE TURNED OFF AND THE SPRING RELEASED BEFORE ENTERING THE TRAP HOUSE. NEVER ATTEMPT TO MAKE ANY ADJUSTMENT WHILE THE THROW ARM IS COCKED.**

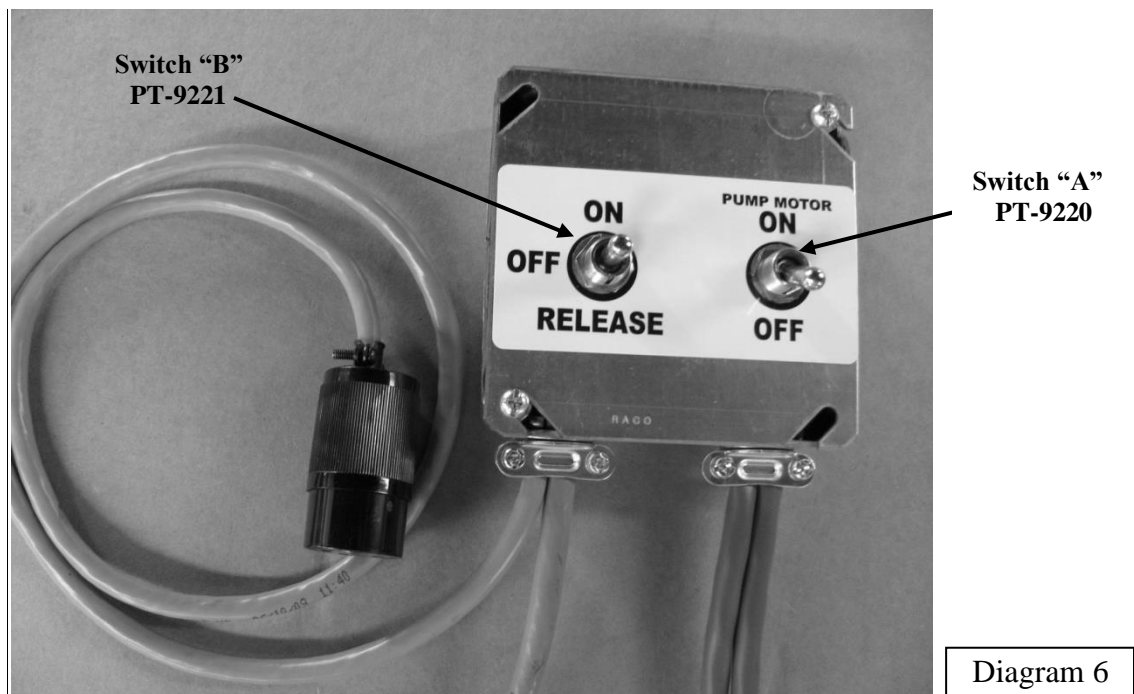

**Close Up of Pat-Trap® Power Control Box (PT SP80)**



## CONNECTING THE TRAP TO THE POWER SOURCE

1. Check the power control box to confirm that the *motor* and the *on/off/release* switches are in the **OFF** position. When both toggle switches are snapped downward they are in the OFF position (Diagram 6).
2. Connect the pump to the power control box by plugging the pump motor outlet coming from the power control box.
3. The trap machine uses 110 volt AC power, (15 AMP; 60 Hz; 1650Watts). Connect the trap machine to the power source using the male plug from the power control box.
4. Connect the pull cord to the female connector from the power control box. The pull cord must have a male twist lock connector (Winchester type pull cord).

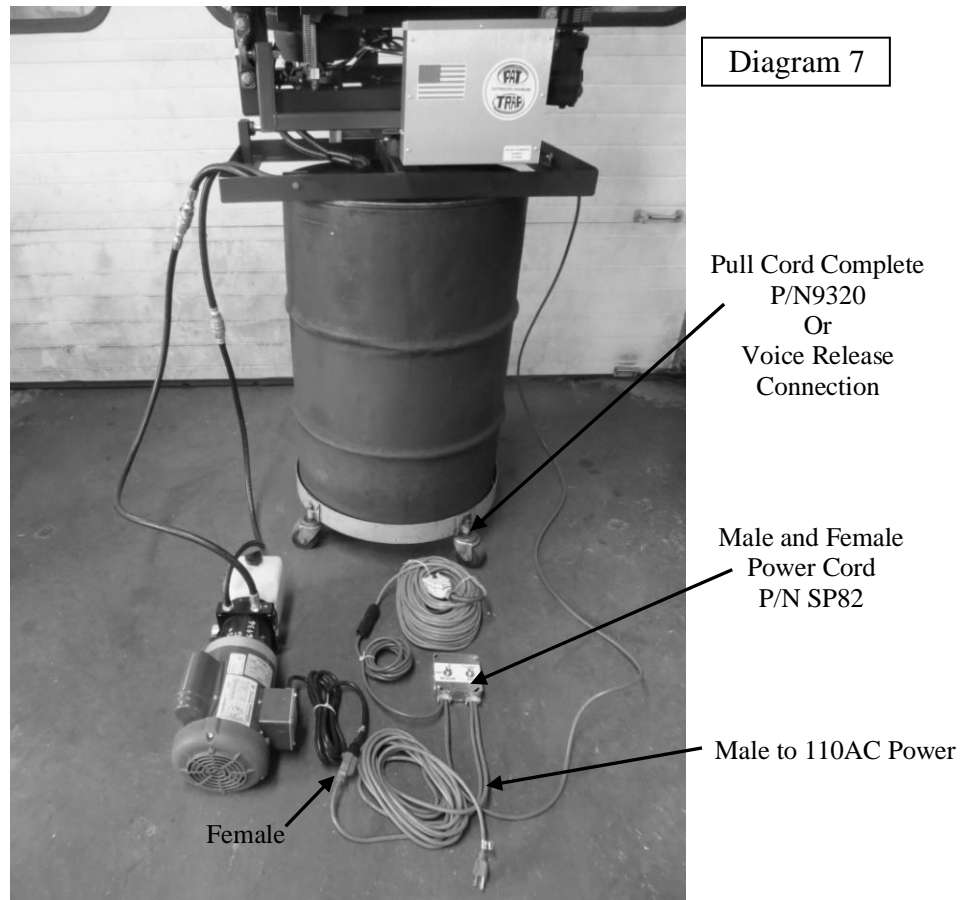



## HOW THE PAT-TRAP® AUTOMATIC DOUBLES MACHINE WORKS

Turn the switch marked “Pump Motor” to the On Position, and let the pump warm up.

Turn the switch marked “On/Off/Release” to the On Position to energize the PAT-TRAP®. The elevator rises to receive a target while the throw arm and turret advance. When a target is loaded, the elevator goes down and the throw arm advances the target until the Activator comes to the #2 and #3 switch bracket (See Diagram 9). The throw arm is now at the brake (in the cocked position - Diagram 8) and the target is set.



Diagram 8

**Throw Arm on Throw Arm Brake**

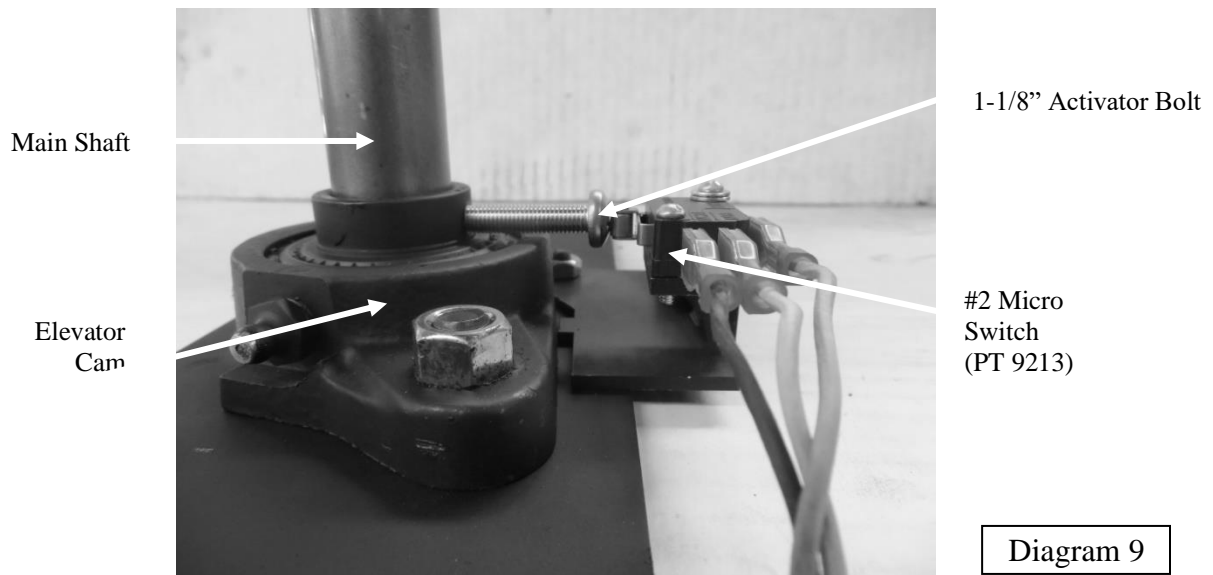

Diagram 9

**Pat-Trap® #2 Switch Bracket in “ON Position”**



When the trap release switch is activated (pull cord or voice release system), Switch #1 overrides Switch #2 which then advances the throw arm off the throw arm brake causing the machine to fire and initiate the oscillation cycle. The oscillation cycle can also be activated by pushing the On/Off/Release toggle switch all of the way down to Release and then back up to the On position. (See Diagram 11)

When the activator leaves Switch #2, the #2 switch closes and begins a new cycle of loading a target and at the same time starts a new cycle of the oscillation interrupter.

\*\* The machine oscillates to the left until Switch #12 (Left Angle Limit Reed Switch - N.O.) comes to the magnet, activating the SS circuit, causing the machine to change direction to the right (Diagram 10).

Switch #11 holds the Circuit engaged until Switch #11 (Right Angle Limit Reed Switch - N.O.) comes to the magnet, breaking the circuit which then switches the circuit causing the machine to oscillate back to the left. (Diagram 79)



**Pat-Trap® #12 & #11 Limit Reed Switches on Oscillation Cylinder**

**Diagram 10**

The switching sequence is the same for the wobble machine.

**Diagram 11**

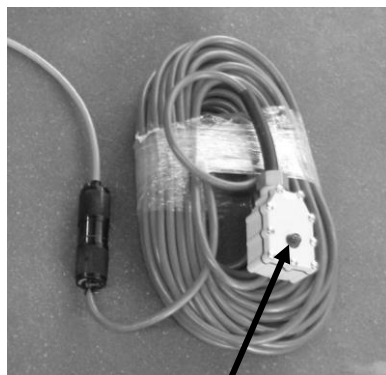

**#1 Switch Trap Release Switch**

**Wobble Cylinder PT-9013M**

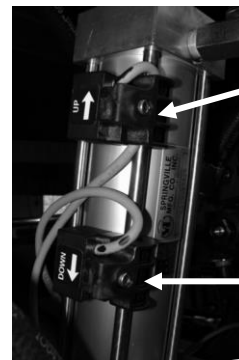

**“UP” Limit Reed Switch #11A (N.O.) PT-9222**

**“DOWN” Limit Reed Switch #12A (N.O.) PT-9222**

**Diagram 12**

**#11A & #12A Limit Reed Switches on Wobble Cylinder**



### **PAT-TRAP® SWITCH IDENTIFICATION.**

Switch #A	PAT-TRAP® Pump Motor Switch (See Diagram 6)
Switch #B	PAT-TRAP® On/Off/Release Switch (See Diagram 6)
Switch #1	PAT-TRAP® Trap Release Switch (See Diagram 11)
Switch #2	Throw Arm Limit Switch. (See Diagram 9)
Switch #11	N/O Right-angle Limit Reed Switch. (See Diagram 10)
Switch #12	N/O Left-angle Limit Reed Switch. (See Diagram 10)
Switch #11A	High-angle “UP” N/O Limit Reed Switch (Wobble). (See Diagram 12)
Switch #12A	Low-angle “DOWN” N/O Limit Reed Switch (Wobble). (See Diagram 12)

### **TURNING THE PAT-TRAP® MACHINE “ON”**

1. Push the Pump Motor toggle switch UP to the “ON” position. (Diagram 6)
2. **IMPORTANT:** Turn the pump motor switch on first so that the hydraulic system is pressurized to prevent any air from entering the system. Allow the pump to warm up the hydraulic oil before operating the machine. In warm weather this will not matter. **Cold temperatures may cause the throw arm to cycle repeatedly if the hydraulic oil is not warm.** Please refer to the section: Cold Weather Adjustment Temperature/Release Time and stopping the Throw Arm on the brake.
3. Push the On/Off/Release toggle switch UP to the “ON” position. (Diagram 6)

### **TURNING THE PAT-TRAP® MACHINE OFF**

1. Standing outside, and to the side of the trap house, push the On/Off/Release toggle switch all the way DOWN to release and let go. The trap will throw the target and not cock the spring.
2. Push the Pump Motor toggle switch DOWN to the Off position.





## LOADING THE PAT-TRAP® MACHINE

The Pat-Trap® machine holds four (4) full cases of clay targets. (540 Targets)

NEVER attempt to load the clay targets without first releasing the trap machine.

NEVER STAND IN FRONT OF A TRAP MACHINE. THE TRAP MACHINE MUST BE TURNED OFF AND THE SPRING RELEASED BEFORE ENTERING THE TRAP HOUSE. NEVER ATTEMPT TO MAKE ANY ADJUSTMENT WHILE THE THROW ARM IS COCKED.

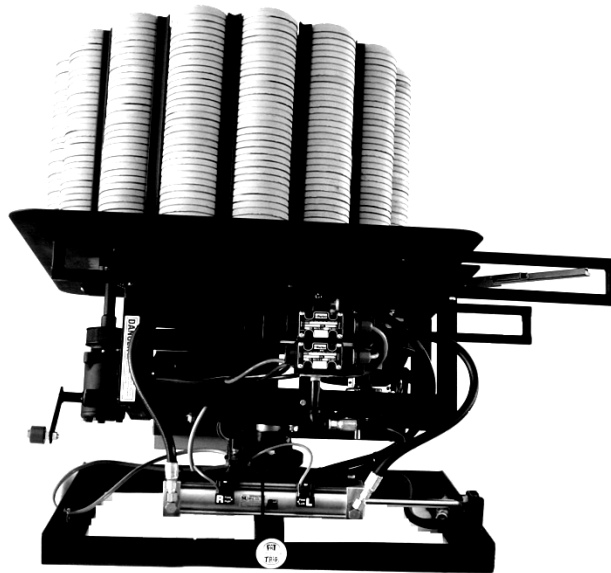
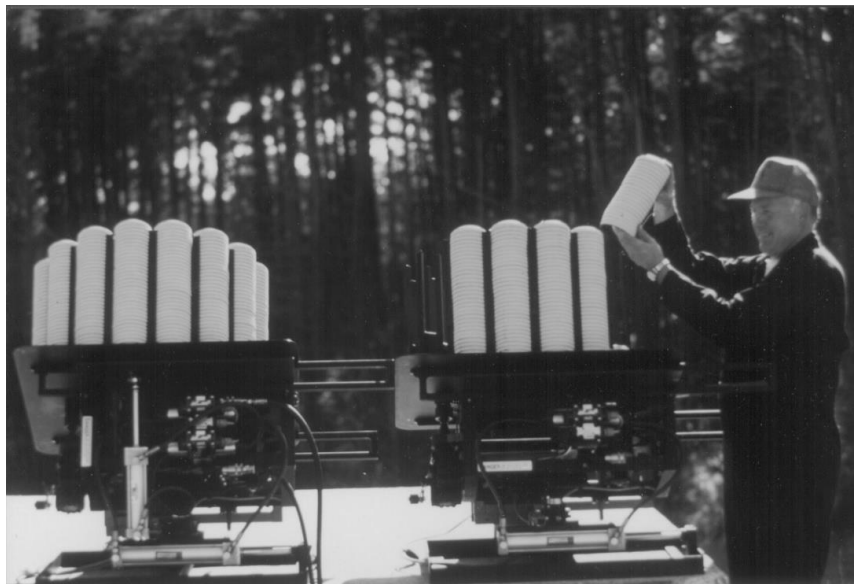

Diagram 14

**Fully Loaded Pat-Trap® Machine**



**Stuart W. Patenaude, the Inventor of the Pat-Trap®,**



**loading an early Pat-Trap® Machine.  
AUTOMATIC PAT-TRAP® SINGLES**

NEVER STAND IN FRONT OF A TRAP MACHINE. THE TRAP MACHINE MUST BE TURNED OFF AND THE SPRING RELEASED BEFORE ENTERING THE TRAP HOUSE. NEVER ATTEMPT TO MAKE ANY ADJUSTMENT WHILE THE THROW ARM IS COCKED.

1. Standing clear of the trap machine, release the target. Push the On/Off/Release toggle switch all the way down to the release position and then let go of it.
2. Pull back on the roller plate and move the set pin to the lower notch. (See Diagram 15)

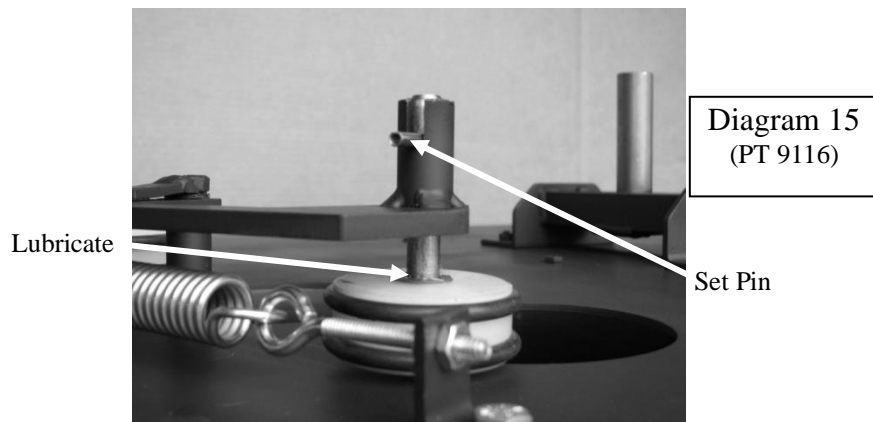

**Singles/Doubles Roller Plate in “Singles” Position**

3. Set the Elevator Cog to the appropriate notch for singles. (Diagram 19)
4. The main spring tension can be adjusted by rotating the main spring crank clockwise to increase tension and counter-clockwise to reduce the tension. When changing from Doubles to Singles, rotate the main spring crank counter-clockwise the same number of turns that were used to increase the tension for Doubles --- approximately 10 rotations. (Diagram 16)

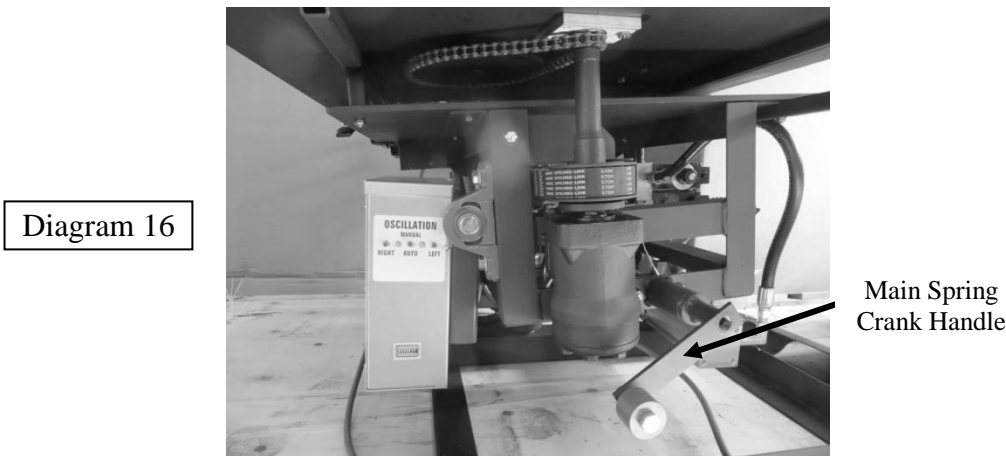

**Main Spring Crank Handle**



5. On the trap machine electrical box, the toggle switch must be pushed down to the Auto position. This will return the machine to automatic horizontal oscillation. (See Diagram 17)



Diagram 17

**Electrical Enclosure (“Auto” Position)**

6. Before exiting the trap house, staying clear of the trap, reach over to the power control box and release the target to prevent target releasing. (Diagram 6)
7. Standing outside of the trap house and to the side, push the On/Off/Release toggle switch up to the ON position. (Diagram 6)



## AUTOMATIC PAT-TRAP® DOUBLES

NEVER STAND IN FRONT OF A TRAP MACHINE. THE TRAP MACHINE MUST BE TURNED OFF AND THE SPRING RELEASED BEFORE ENTERING THE TRAP HOUSE. NEVER ATTEMPT TO MAKE ANY ADJUSTMENT WHILE THE THROW ARM IS COCKED.

1. Standing clear of the trap machine, release the target. Push the On/Off/Release toggle switch all the way down to the release position and then let go of it..
2. Pull back on the Roller Plate and move the set pin to the upper notch. (Diagram 18)

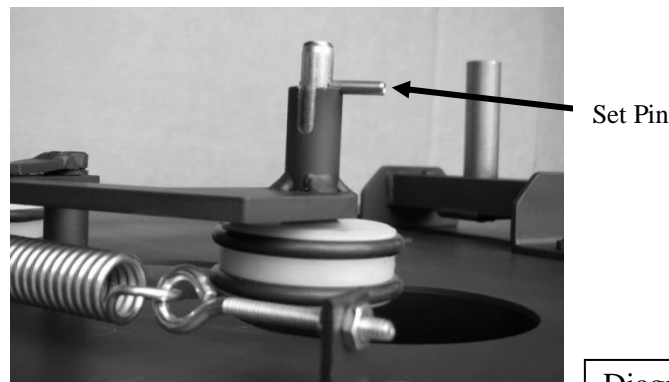

Diagram 18

### Singles/Doubles Roller Plate in Doubles Position

3. Raise the elevation of the trap by placing the bottom portion of the trap machine into the elevation cog approximately 3-4 notches above the notch used to establish the Singles height. For example if the 10<sup>th</sup> notch was used in Singles then the Doubles setting should be approximately the 13<sup>th</sup> or 14<sup>th</sup> notch on the Elevation Cog nearest the frame. (Diagram 19) to achieve the 23° angle.

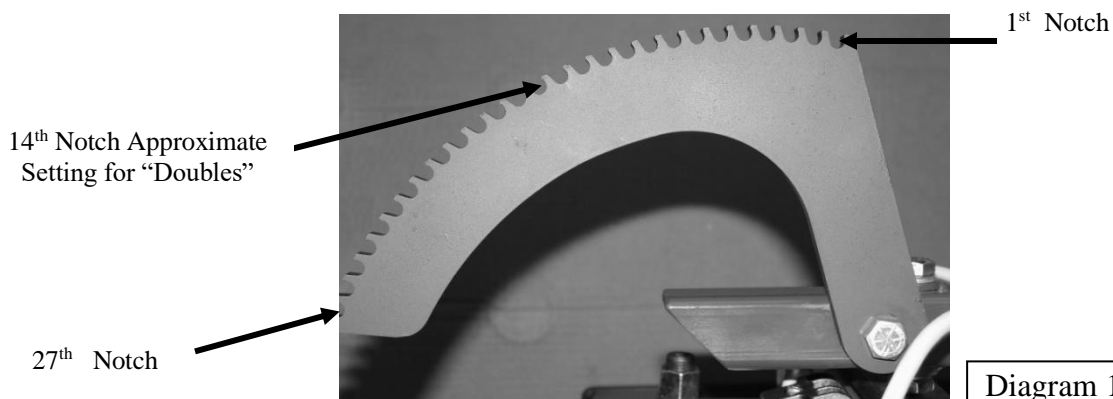

Diagram 19

### Elevation Cog



4. The spring tension must be *increased* to throw Doubles. Rotate the spring crank *clockwise* approximately 10 rotations from the Singles setting. (Diagram 16).
5. On the trap machine electrical box, the toggle switch must be pushed up to the Manual position (Diagram 17). This will stop the automatic horizontal oscillation and will activate the Right and Left pushbuttons. The trap machine must be ON to operate the Right and Left pushbuttons. When the trap is On the throw arm is ready to fire. The throw arm can be fired by pushing the pullcord button. It can also be fired by hand: by pushing the arm forward off the brake when the machine is either On or Off. Staying clear of the trap machine, reach over to the power control box and turn the On/Off/Release switch to the ON position.
6. Use the Right or Left button to move the trap machine to the center of the trap field.
7. Before exiting the trap house, staying clear of the trap, reach over to the power control box and release the target.
8. Standing outside of the trap house and to the side, push the On/Off/Release toggle switch up to the ON position.

### **ADJUSTMENT FOR PAT-TRAP® DOUBLES**

The adjustment for Doubles should only need to be done the very first time the machine is used. Using a 7/16" wrench, loosen the bolt, move the Double Finger in 1/8" increments. Pull the Doubles Finger back towards self to lower the height of the right target. Push it forward to raise the height of the right target. Tighten the bolt. See Diagram 20. Refer to the section for correct positioning of the Doubles Finger (Page 37). (Although the bolt is snug, it is possible to move the Doubles Finger without loosening the bolt.)

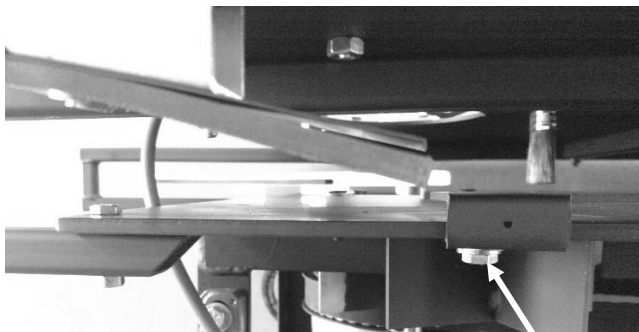

Diagram 20

Bolt

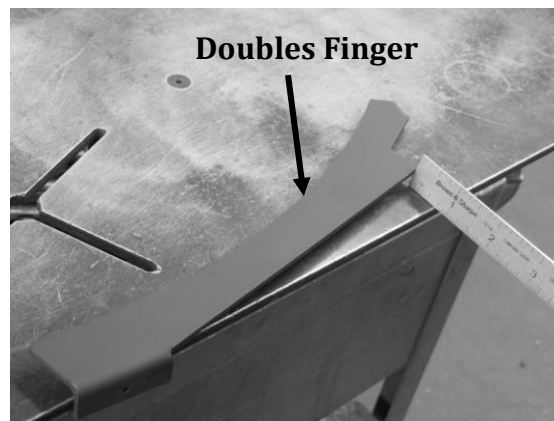

Diagram 21



### AUTOMATIC PAT-TRAP® WOBBLE SETTINGS

The PAT-TRAP® with Wobble can be used in any of the following modes:

**STATIONARY**

- X Singles
- X Doubles

**OSCILLATING HORIZONTAL**

- X Singles
- X Doubles

**OSCILLATING VERTICAL**

- X Singles
- X Doubles

**OSCILLATING HORIZONTAL/VERTICAL**

- X Singles
- X Doubles

The PAT-TRAP® with Wobble has an interrupter for the horizontal and vertical modes.

NOTE: If the machine is located inside a trap house, oscillating doubles targets may hit the trap house walls.

### WOBBLE ANGLES

Left/Right Angle = 8" => 50°  
Down Angle = 7° Min

Left/Right Angle = 10" = 60°  
Up Angle = 25 ½ ° Max

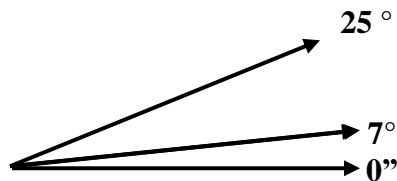



## CHANGE OVER TO WOBBLE

Standing clear of the trap machine, release the target. Use all safety procedures as stated in the previous Singles and Doubles section of this Manual.

The Oscillation Switch and the Wobbles Switch must be pushed down to the AUTO position on the trap machine electrical enclosure. This engages the machine to the automatic horizontal/vertical oscillation mode.

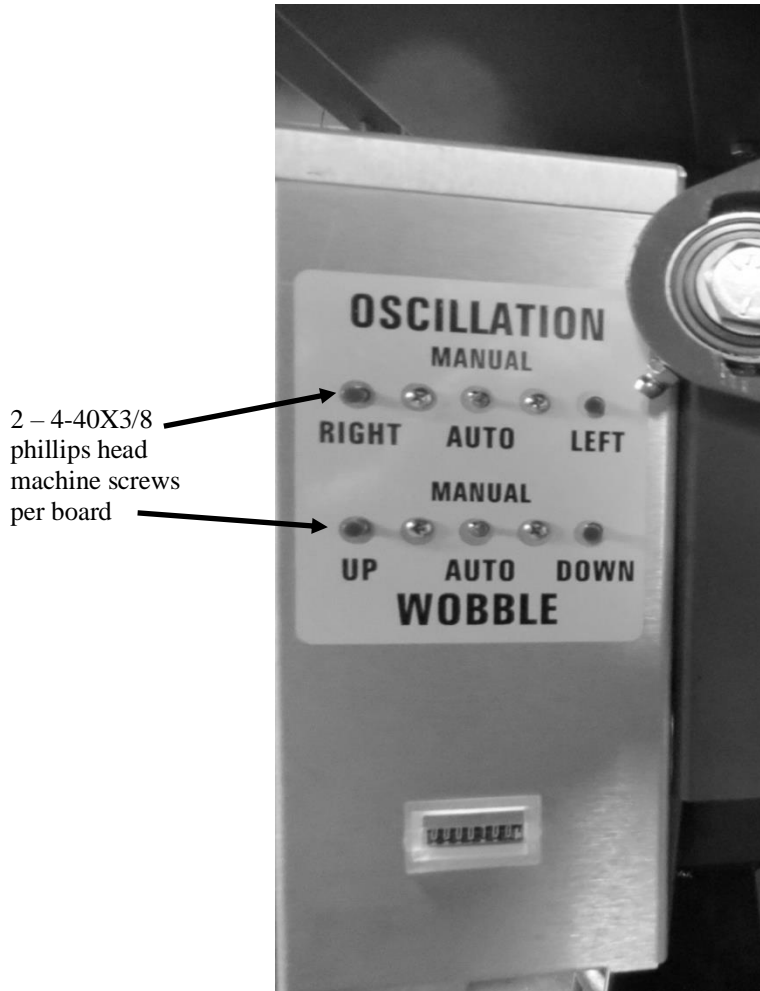

Diagram 22



## HEIGHT ADJUSTMENT FOR SINGLES/DOUBLES ON A WOBBLE MACHINE

On the trap machine electrical box, the horizontal switch must be moved to the MANUAL position. For desired height, push UP switch to go up; push DOWN switch to go down.

## INCREASING/DECREASING TARGET DISTANCE/SPEED

Clockwise rotation of the main spring crank handle increases the spring tension thus increasing the speed of the target and the distance it travels.

Counter clockwise rotation of the main spring crank handle decreases the spring tension. Continued counter-clockwise rotation will remove the tension from the crank and the spring tension lock-nut will hold. The elastic lock-nut holds the spring at the set minimum tension.

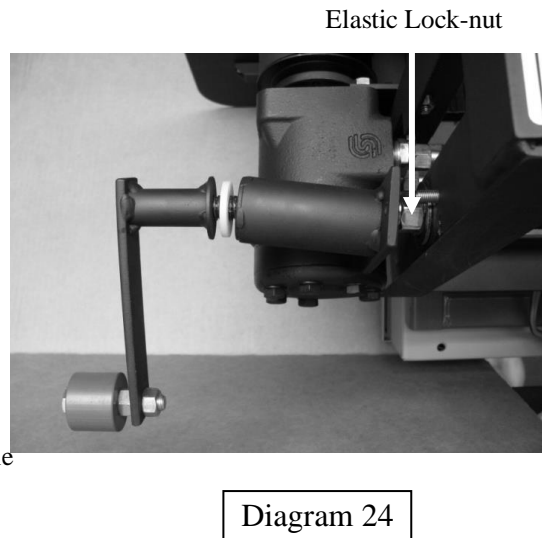
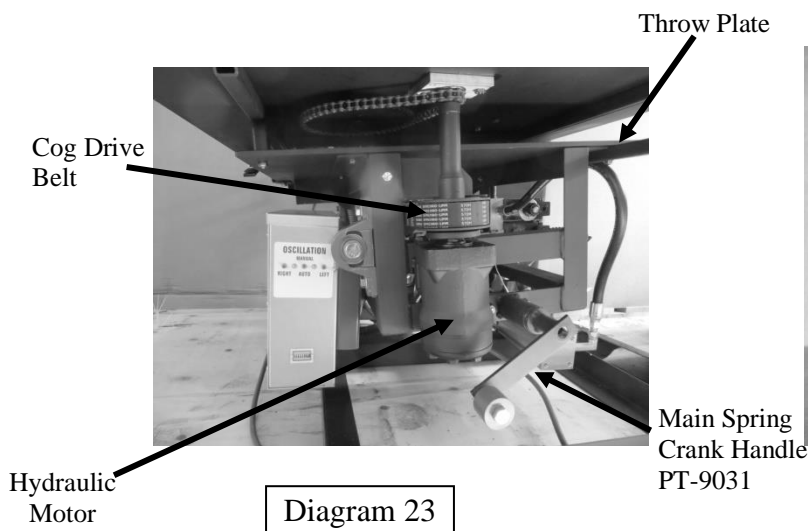

### PAT-TRAP® Main Spring Crank Handle





## **SETTING MINIMUM TARGET DISTANCE**

The procedure to establish the minimum distance for a “Singles” target is as follows: (the standard trap speed is 67 to 70 FPS to throw a target 49 to 51 yards with the machine angled at 20 degrees (9 ft high and 30 ft out) (For a 45 yard Doubles target set a Single target at 76 FPS

1. Remove the main spring crank handle by rotating it counter-clockwise (Diagram 25).
2. Remove the nylon washer that is sandwiched between the crank handle and the stand-off collar sleeve (Diagram 25).

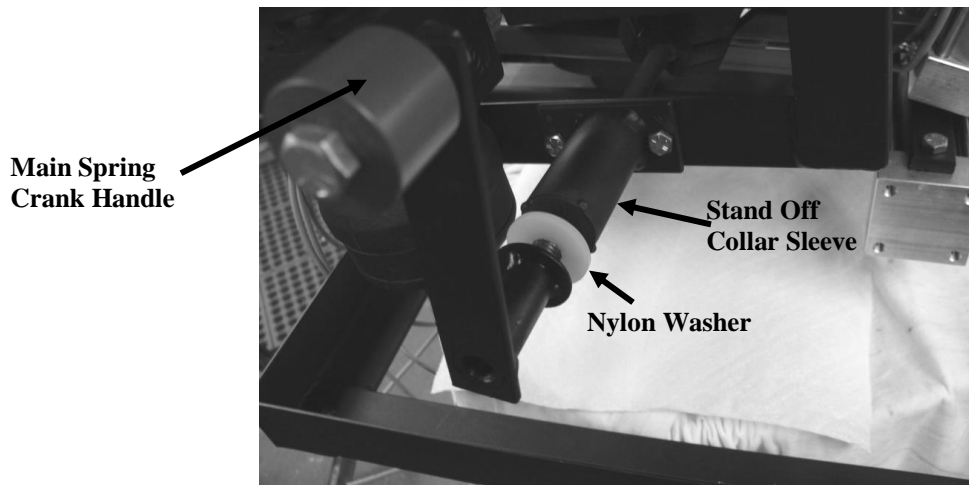

### **Backing off the tension on PAT-TRAP® Main Spring Crank Handle**

3. Remove the two (2) 1/4” bolts from the stand-off collar sleeve (Diagram 26 )

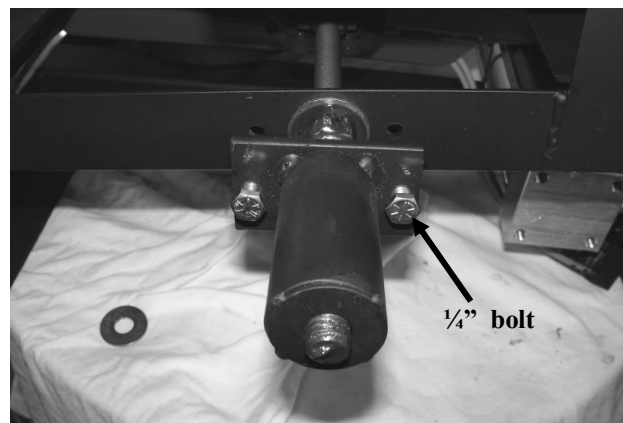

### **Removing Main Spring Standoff Collar Sleeve**

4. Remove the stand-off collar sleeve (Diagram 26).
5. Locate the elastic lock-nut. Use a 3/4” wrench on this nut to adjust the distance/speed (Diagram 27)



**Adjusting Elastic Lock Nut with 3/4" Wrench**

6. At this point one can throw a target or two to establish how far the PAT-TRAP® is currently throwing a straight away “Singles” target. Please observe the proper safety precautions.
7. When proper/desired distance/speed is achieved, back off the elastic lock-nut three (3) turns.
8. Re-assemble the parts.
9. When the main spring crank handle becomes snug, continue to turn three (3) more times for the proper setting.
10. Note: Whenever a “Singles” distance is to be set, back off the crank to neutral, crank back to snug; then give another three (3) turns for proper setting.

NEVER STAND IN FRONT OF A TRAP MACHINE. THE TRAP MACHINE MUST BE TURNED OFF AND THE SPRING RELEASED BEFORE ENTERING THE TRAP HOUSE. NEVER ATTEMPT TO MAKE ANY ADJUSTMENT WHILE THE THROW ARM IS COCKED.

**NOTE: “SINGLES” are always set first, and then follow the procedures for “Doubles” as outlined.**



## ADJUSTMENT HEIGHT OF TARGETS

NEVER STAND IN FRONT OF A TRAP MACHINE. THE TRAP MACHINE MUST BE TURNED OFF AND THE SPRING RELEASED BEFORE ENTERING THE TRAP HOUSE. NEVER ATTEMPT TO MAKE ANY ADJUSTMENT WHILE THE THROW ARM IS COCKED.

Tilt the table by pushing up on the front of the machine. The elevation cog can be positioned up or down.

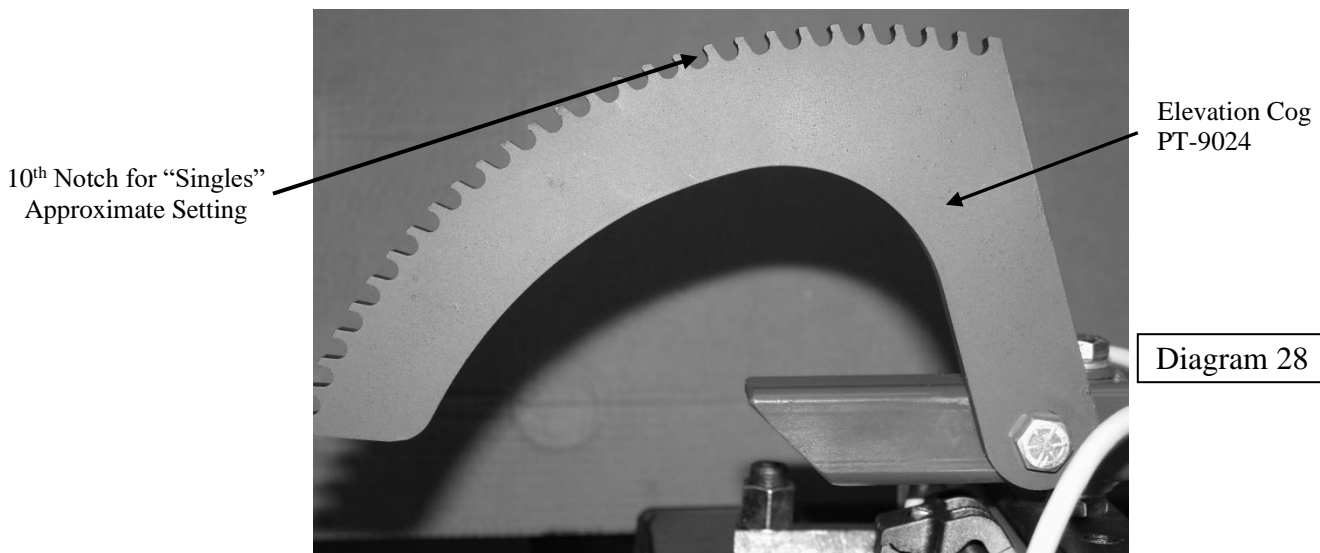

**Elevation Cog on Front of PAT-TRAP®**



## ANGLE ADJUSTMENTS

### STRAIGHT-AWAY TARGETS

Set the toggle switch to the manual position, Use the right and left buttons to achieve Straight-Away Targets.



Diagram 29

Toggle Switch

### 2 – HOLE TARGETS

The 4 1/4" spacer bar between the Left and Right Angel Reed Switches allows for a 5 7/8" of total cylinder rod travel, which equals a **Two-Hole (34°)** Target.

A 5 1/4" spread between the switches allows for a 6 7/8" of total cylinder rod travel, which equals a **Three-Hole (40°)** Target.



2-Hole  
Spacer Bar

#12 Left Angle  
Limit Switch (N.O.)  
PT-9222

Diagram 30

#11 Right Angle  
Limit Switch (N.O.)  
PT-9222



SHIFTING THE TARGET FIELD

The 9/64” hex head set screws on the limit switches are already pre-set.

**DO NOT OVERTIGHTEN AS THE PLASTIC BRACKET WILL BREAK!**

An aluminum spacer bar that is 4 ¼” long is provided for setting a “2-Hole” target field width (See Diagram 30). The field can be adjusted by sliding the limit switches together with the spacer bar in the direction you want to move the field;  
**TO MOVE THE ENTIRE FIELD TO THE RIGHT, SLIDE THE SWITCHES TO THE RIGHT AS YOU ARE FACING THE MACHINE.** Keep the switches against the spacer bar to maintain the proper field width. The set screws are lightly set so that you can slide the limit switches without adjusting the set screws.

To be able to go back to the original setting use a magic marker to draw a line on the cylinder beside the switch to mark where the switches should go back to.



## POSITION OF THE ROLLER PLATES

The roller plate must be positioned as shown. The measurement to both of the roller plates is taken from the face of the kingpin shaft to the inside edge of the roller wheel bolt. See Diagram

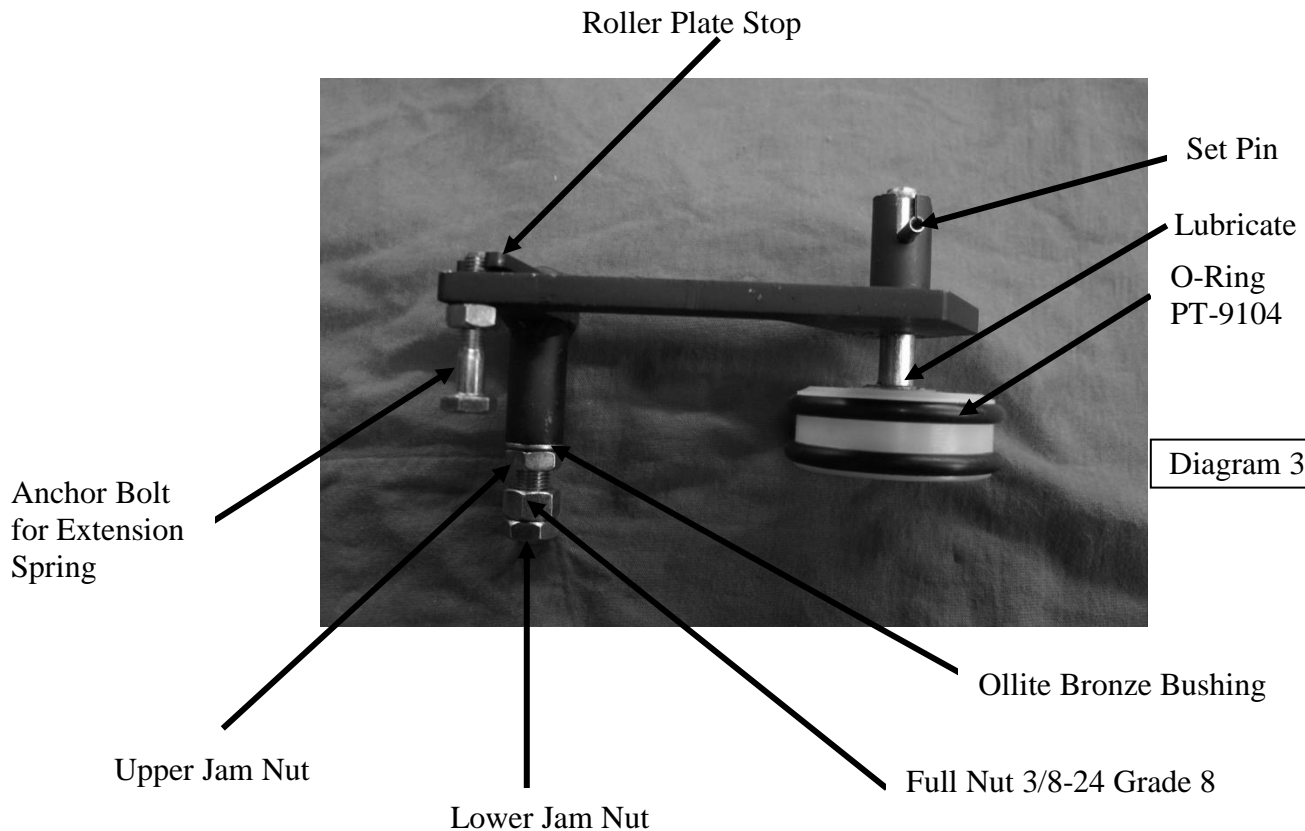

If an adjustment is necessary, then the roller plate stop will have to be turned until the roller plate stops at the given measurement.

To set the position of the roller plate stop:

1. Remove the extension spring
2. Adjust upper jam nut so that when the nut is tightened the roller plate will pivot freely: with no more than 1/32" of up/down play between the roller plate shaft and jam nut.
3. Use an adjustable wrench to turn the roller plate stop to the correct position,
4. Hold back on the roller plate stop with the adjustable wrench while tightening the Full nut. Torque nut to 35/40 ft/lbs.
5. Tighten jam nut against full nut while holding back against the roller plate stop with the adjustable wrench. Torque jam nut to approximately 15 ft/lbs.
6. Check for free pivot of the roller plate after tightening.
7. Reconnect the extension spring.
8. Check the measurement to each roller plate from the king pin.



Extension  
Spring



Diagram 32

13 7/8"

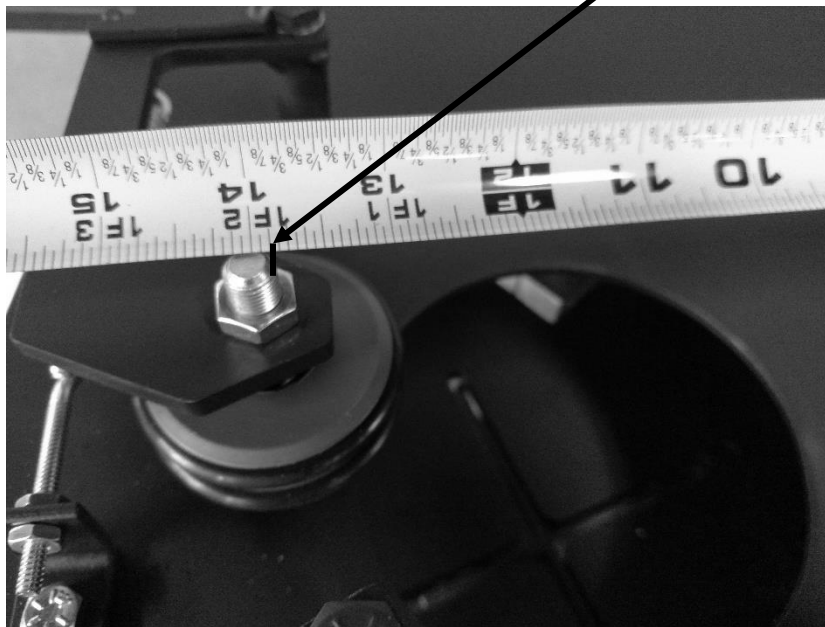

Diagram 33

Singles Roller Plate measurement is 13 7/8" from face of Kingpin Shaft to inside face of the Single Roller Wheel bolt.

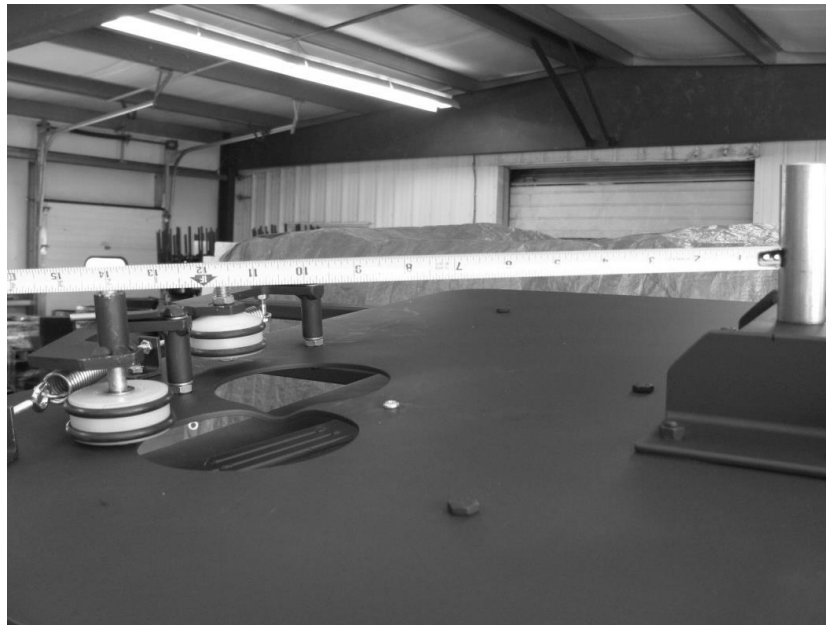

Diagram 34

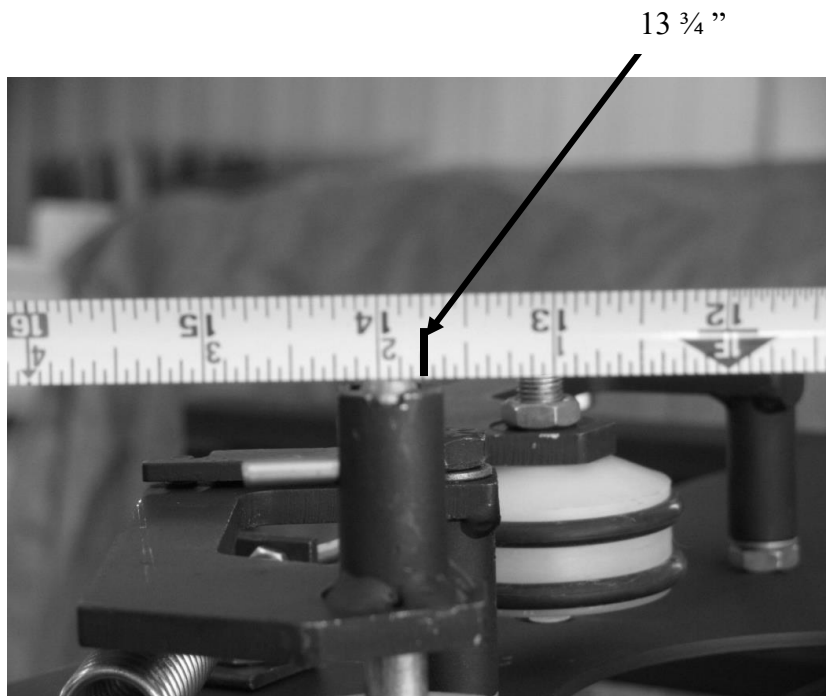

Diagram 35

Doubles Roller Plate measurement is 13 ¾” from the face of the Kingpin Shaft to the inside face of the Doubles Roller Wheel bolt.





## TARGET BRUSH MAINTENANCE

When Targets start to break or Targets are being thrown further to the right, it may be time to change the target brush. When the target brush becomes worn out, the target can be bumped ahead and/or “slide down” the throw plate. This can cause either the target to break or be thrown further to the right.

The purpose of the target brush is to hold the target against the throw arm when the throw arm advances to the cocked position.

When the brush begins to “flair out”, loosen the screw and turn the brush 180 degrees. The brush needs to be aligned with the narrow side of the brush running from front to back of the Pat-Trap<sup>®</sup> Machine as shown in Diagram 36 below. Replace the Target Brush when needed.

Diagram 36

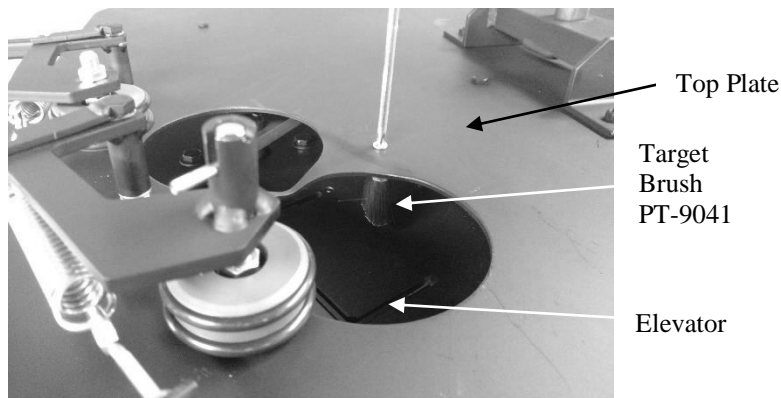

### Installation of New Target Brush

The turret does not have to be removed to replace the target brush. Just remove the targets and use a phillips screw driver to remove the brush.



## **COLD WEATHER ADJUSTMENT TEMPERATURE/RELEASE TIME STOPPING THE THROW ARM ON THE BRAKE**

NEVER STAND IN FRONT OF A TRAP MACHINE. THE TRAP MACHINE MUST BE TURNED OFF AND THE SPRING RELEASED BEFORE ENTERING THE TRAP HOUSE. NEVER ATTEMPT TO MAKE ANY ADJUSTMENT WHILE THE THROW ARM IS COCKED.

In very cold weather, the pump motor should be turned on 30 to 60 minutes before operating time to warm up the hydraulic oil. If the On/Off/Release switch is turned on too soon, the machine will keep cycling (throwing targets).

Extreme temperature changes may affect the stopping position of the throw arm. Very cold temperature may cause the machine to keep cycling by itself. Very warm weather may cause the throw arm to stop too soon and cause slow pulls.

Refer to the Diagram 37 which shows the throw arm brake assembly and the proper stopping position of the throw arm. Note: The Throw Arm is approximately 1" back from the right edge of the Throw Arm Brake Rubber Pad.



Diagram 37

**Correct Position for Stopping the Throw Arm on the Throw Arm Brake**



## ADJUSTING RELEASE TIME - CORRECTION OF CYCLING PROBLEM

To Adjust the Release Time, Correct a Cycling Problem, or Compensate for Extremely Cold Weather.

1. NEVER STAND IN FRONT OF A TRAP MACHINE. THE TRAP MACHINE MUST BE TURNED OFF AND THE SPRING RELEASED BEFORE ENTERING THE TRAP HOUSE. NEVER ATTEMPT TO MAKE ANY ADJUSTMENT WHILE THE THROW ARM IS COCKED.
2. Locate the two switch (#2 Micro Roller Switches) on the bottom left side of the trap machine which are mounted on an adjustable bracket. Diagram 38.
3. Loosen the thumb screw to allow the switch bracket to move forwards or backwards. Diagram 39.
4. Move the upper portion of the switch bracket (diagram 39) by increments of 1/16" to the left (forward towards the front of the trap house) to stop cycling --- or lengthen the throw time --- causing the arm to stop further back on the throw arm brake.
5. To shorten the throw time (release time), move the switch bracket to the right --- toward the back of the trap house --- causing the throw arm to stop further forward on the brake.
6. For proper stopping position of the throw arm on the brake see Diagram 37.

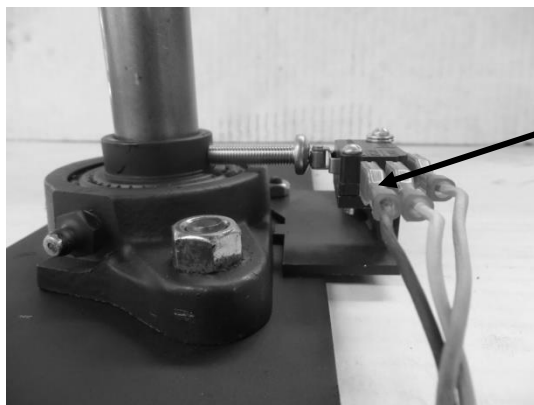

**Side View of #2 Switch Bracket**

Diagram 38

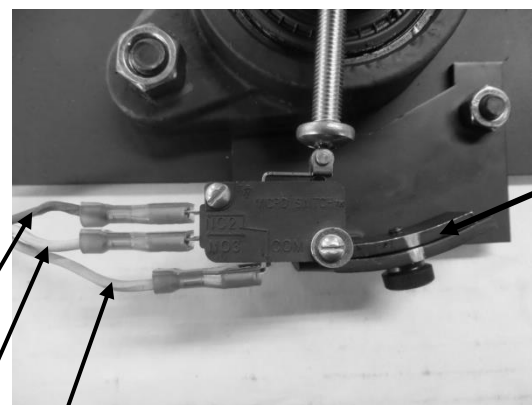

**Top View of #2 Switch Bracket**

Diagram 39

#2 Micro Switch (PT 9213)

Switch Bracket

Black (NC)

White (NO)

Green (Common)



## ASSEMBLY AND MAINTENANCE OF THE THROW ARM BRAKE

A worn out brake rubber or broken brake flat spring will allow the throw arm to fire through (i.e., cycle) thereby throwing uncalled for targets.

Keep surfaces dry where the throw arm contacts the brake rubber.

Replace the throw arm brake rubber when it begins to wear out. See Diagram 4.4.

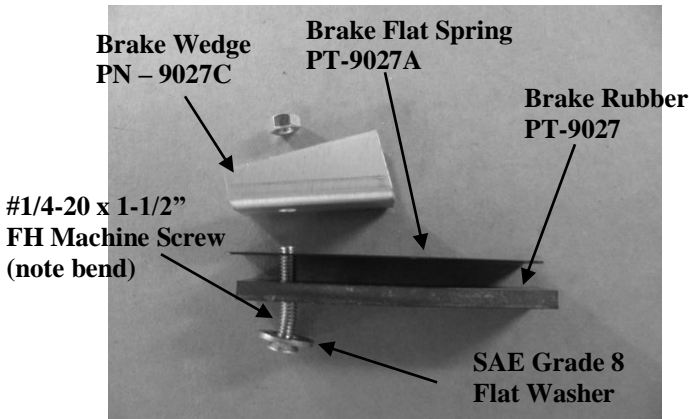

Diagram 40

### Components of Throw Arm Brake Assembly

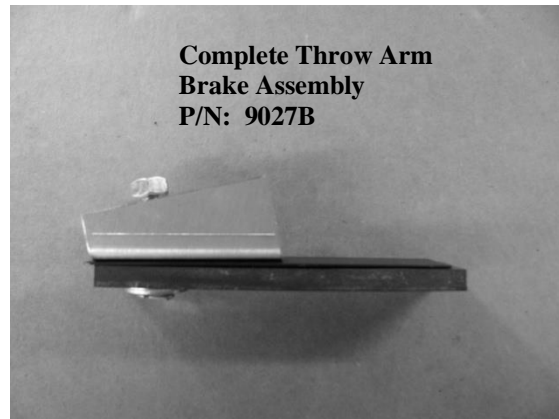

Diagram 41

NOTE: The proper stopping position for the throw arm on the throw arm brake is shown in Diagram 42, which is approximately one inch from the right hand side of the brake rubber.



Throw Arm  
Brake  
Assembly  
PN - 9027B

Diagram 42

### Throw Arm in "Cocked Position" on Throw Arm Brake Assembly



## REMOVAL OF THROW ARM

NEVER STAND IN FRONT OF A TRAP MACHINE. THE TRAP MACHINE MUST BE TURNED OFF AND THE SPRING RELEASED BEFORE ENTERING THE TRAP HOUSE. NEVER ATTEMPT TO MAKE ANY ADJUSTMENT WHILE THE THROW ARM IS COCKED.

1. Remove and/or disconnect the main spring. Refer to the **Disconnecting The Uni-Band** section in this manual (Page 34 ).
2. Rotate the throw arm to a place where you can reach the nut. Use a 7/16th socket wrench with a long extension to loosen the 1/4-28 nut on the throw arm (See Diagram 43).
3. Move the arm to the area between the braces. Use a pry bar or a long screwdriver. Place it under the throw arm next to the throw arm shaft and pry up on the throw arm to remove.
4. NOTE: The arm might come off more easily if you wiggle the throw arm, slightly, up and down while prying up.
5. Pry downwards against the underside of the top plate to install the new throw arm.

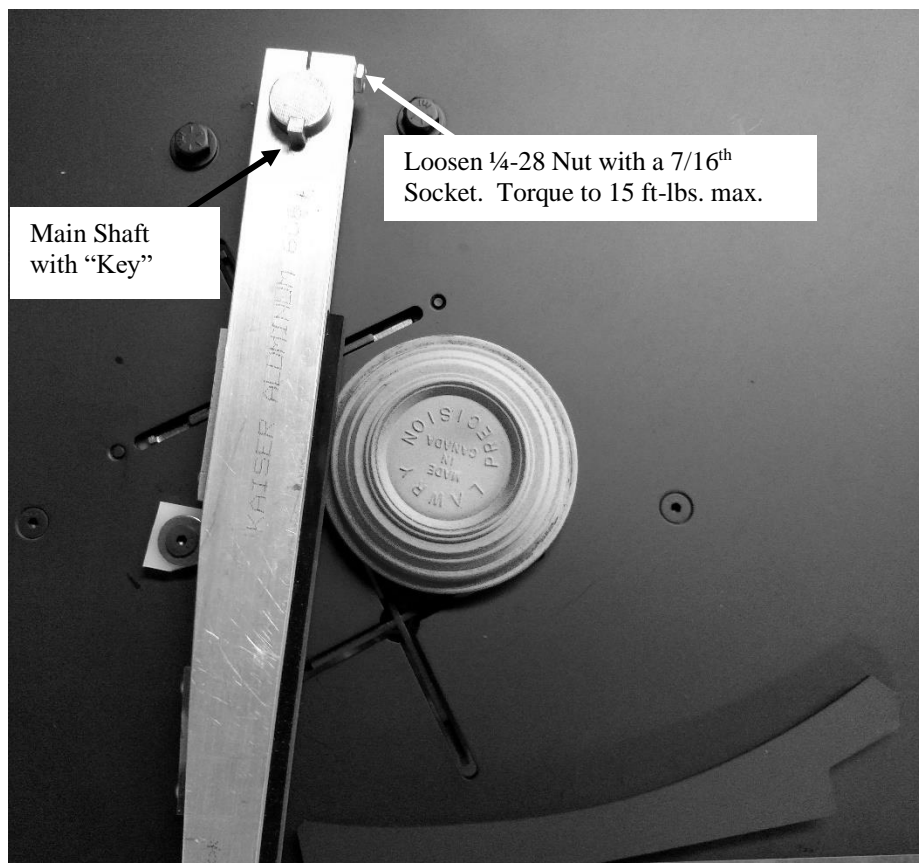

Diagram 43

### **Removal/Installation of Throw Arm (PT-9026)**



## **DISCONNECTING THE UNIBAND FROM THE CLUTCH**

1. Let off the crank handle tension.
2. Turn the machine on to cock the throw arm.
3. When the throw arm stops at the throw arm brake, turn the machine off without releasing the throw arm.
4. **WHEN THE THROW ARM IS COCKED, BE SURE TO STAND BEHIND THE TRAP AND STAY CLEAR OF THE THROW ARM.** To completely release the tension on the throw arm carefully, manually, release the throw arm by first looping a rope or cord around the end of the throw arm. Then, holding back on the rope at 90 degrees to the throw arm, slowly move the throw arm past the brake and guide it around to the front of the machine.
5. Move the throw arm so that it is 6 7/8" from the right hand corner of the throw plate. See Diagram 53.
6. Use a 5/32" allen wrench to loosed the clutch rod-end bolt. Pull down on the rod end to remove. See Diagram 52.

## **INSTALLATION OF THE THROW ARM**

1. Release the throw arm. Never attempt to work on your machine while it is in the cocked position.
2. Turn off the machine and “drop” the machine to the lowest elevation for an easier working position.
3. Disconnect the main spring before working with the throw arm. Refer to the Disconnecting the Uni-Band section in this manual.
4. Place the throw arm on the main shaft in the same place that it was. Hold the throw arm level while tightening the 1/4-28 nut.
5. The height of the bottom of the throw arm rubber needs to be 1/2-inch above the surface of the throw plate. (This measurement allows for 1/32" between the lip of the target and the throw arm rubber.) See Diagram 44 & 45.

Note: Bottom of Throw Arm Rubber is 1/2" Above Throw Plate Surface in the area where the target leaves the throw plate.

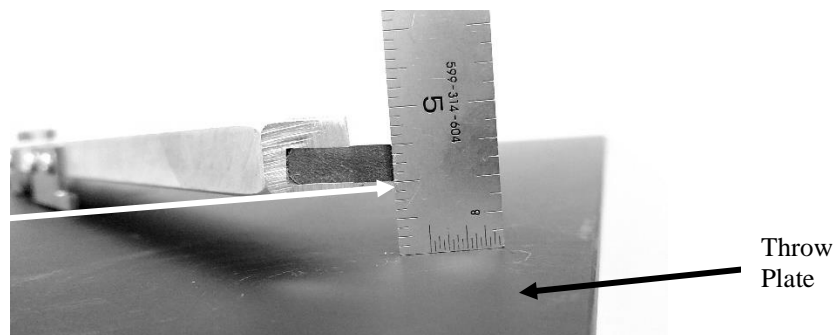

**Setting Correct Height of Throw Arm with a Ruler** Diagram 44



6. With the main spring disconnected, check to be sure that there is 1/32", but no more than 1/16", of clearance between the target and the throw arm through the area that the target travels --- especially the area where the target leaves the throw plate surface. Please refer to Diagram 45.



Diagram 45

**Setting Correct Target Clearance for Throw Arm with a Target**

7. Check to see that the notch on the front rake on the PAT-TRAP® throw arm clears the Doubles Finger. See Diagram 46. To verify the clearance, move the throw arm manually past the brake and through the area of the Doubles Finger to check clearance.
8. If necessary, the Doubles finger can be bent down using a pair of channel-lock pliers. A screwdriver can be used between the "doubles" finger and the throw plate to pry it up if necessary.

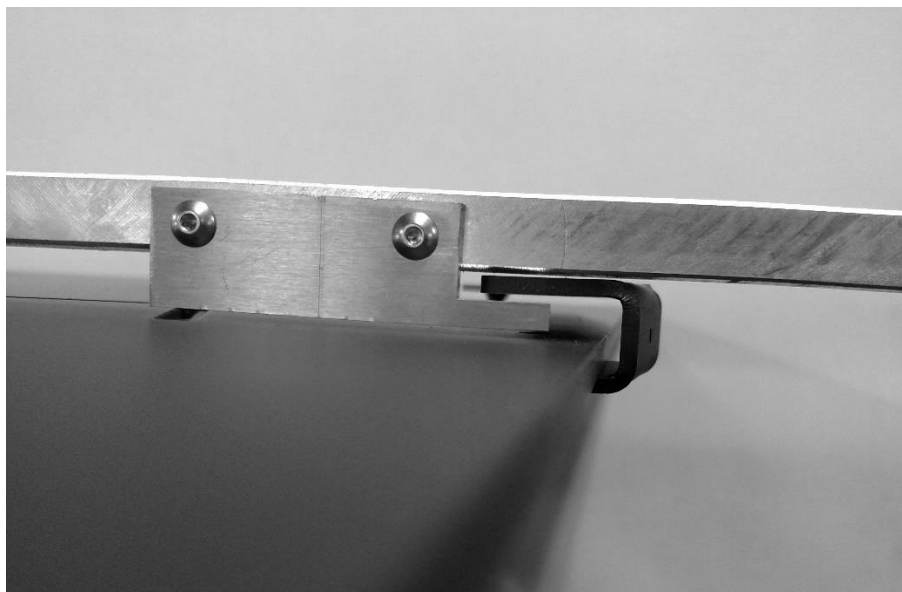

Diagram 46



### MAINTENANCE OF THROW ARM COCKING PIN

The PAT-TRAP<sup>®</sup> machine must be released and turned off before performing any work.

Rotate the bumper 45 degrees (1/8<sup>th</sup> turn) after approximately 100,000 throws (see counter located in the Electrical Control Box) to see if a flat spot is visible. The bumper should be easy to rotate by hand without having to loosen the bolt. Replace the bumper if worn or cracked. Slide the new bumper onto the bolt as pictured in Diagram 47.

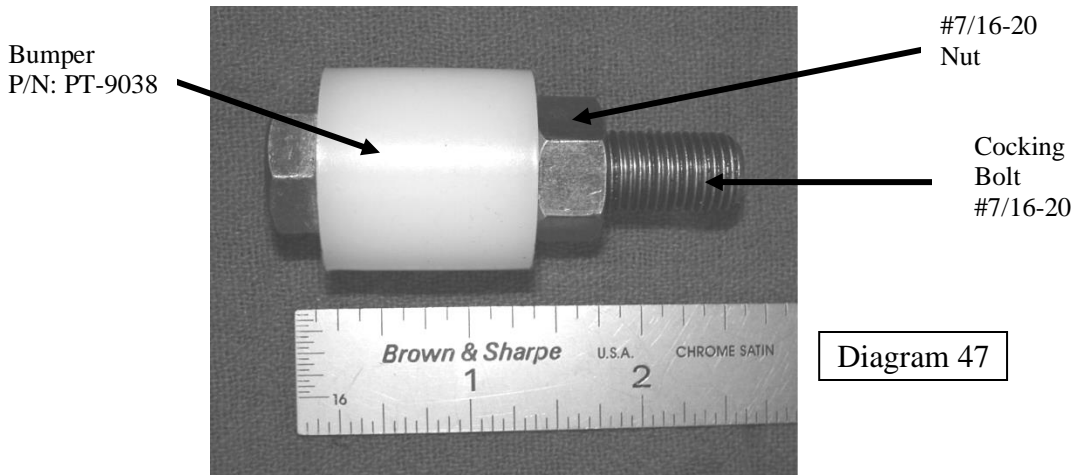

#### Cocking Bolt Assembly (PT-9035)

Turn the nut on by hand until it is against the bumper.

Screw the Cocking Pin Assembly into the bottom of the main cog belt pulley wheel until the nut contacts the wheel. See Diagram 48.

Now, tighten the nut against the main timing wheel very tight. (Torque to 35-40 ft-lbs.). See Diagram 48 below.

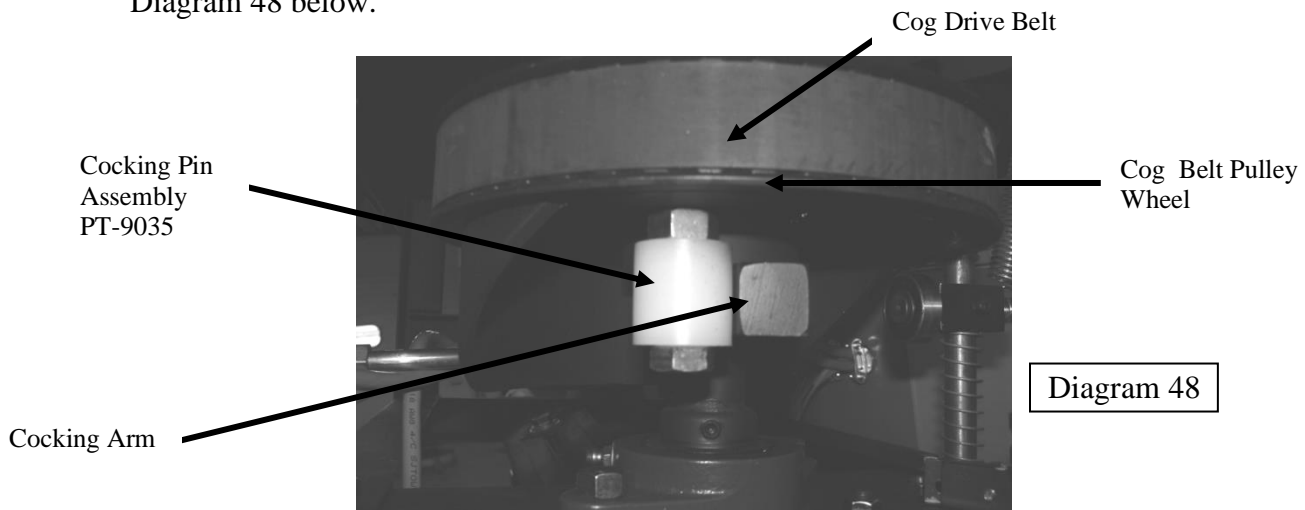

#### Cocking Bolt Assembly (PT-9035) Attached to Timing Pulley

**IMPORTANT:** Do not tighten the bolt against the nut because it will compress the bumper.





## INSTALLATION OF THE “XXX” DOUBLES FINGER & SINGLES FINGER

1. Release the throw arm and turn off the machine.
2. Set the “XXX” Doubles Finger so that the corner of the first step measures approximately  $3/4$ ” inside the edge of the Throw Plate. Tighten the bolt. This is the approximate position of the “XXX” Doubles Finger for level double targets. See attached diagram 49.

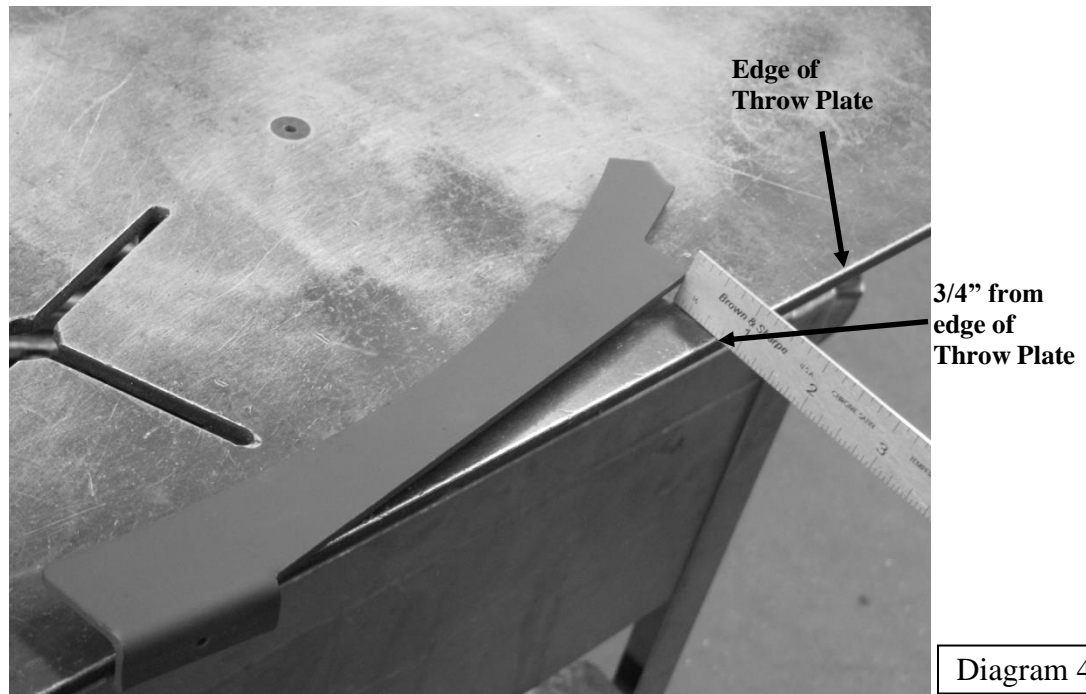

3. Check to make sure that the Singles Finger measures  $4 \frac{3}{8}$ ” from the left-hand end of the “XXX” Doubles Finger. When tightening the nut, hold back on the Singles Finger so that it does not rotate upwards. Diagram 50.

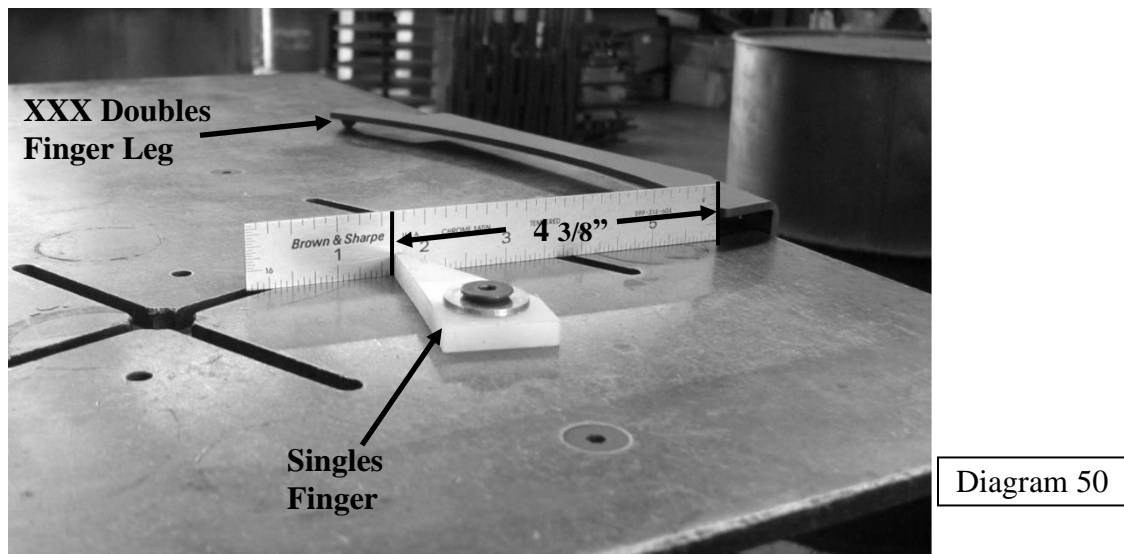



4. Check to see that the Throw Arm clears the “XXX” Doubles Finger.
  - a. Reduce the main spring tension – unwind the crank handle
  - b. Disconnect the main spring – refer to this section in your Machine Manual (page 34).
  - c. Move the Throw Arm manually past the Brake and through the area of the ”XXX” Doubles Finger to check the clearance. Water-pump pliers can be used if the “XXX” Doubles Finger needs to be pried downwards. A long screwdriver can be used if the “XXX” Double Finger needs to be pried upwards.

Presuming the machine is sitting on a level platform, with no wind; these directions should yield a level pair of Doubles.

When installing the XXX Doubles Finger check to make sure that the leg is contacting the Throw Plate surface. If it is not, then remove the finger from the machine and bend down slightly at the opposite end of the finger. (Diagram 50).



## REPLACEMENT/REMOVAL OF MAIN SHAFT CLUTCH ASSEMBLY (PT-9034)

NEVER STAND IN FRONT OF A TRAP MACHINE. THE TRAP MACHINE MUST BE TURNED OFF AND THE SPRING RELEASED BEFORE ENTERING THE TRAP HOUSE. NEVER ATTEMPT TO MAKE ANY ADJUSTMENT WHILE THE THROW ARM IS COCKED.

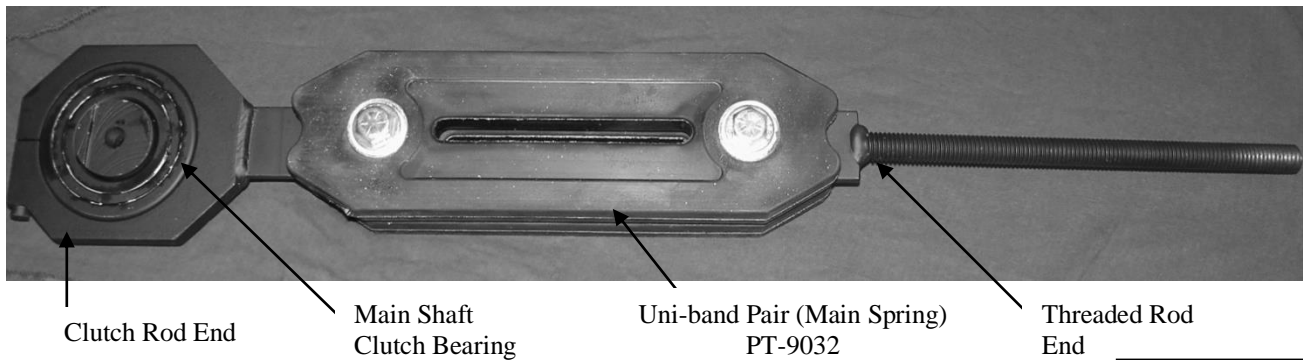

Diagram 51

### Main Shaft Clutch Assembly (PT-9034)

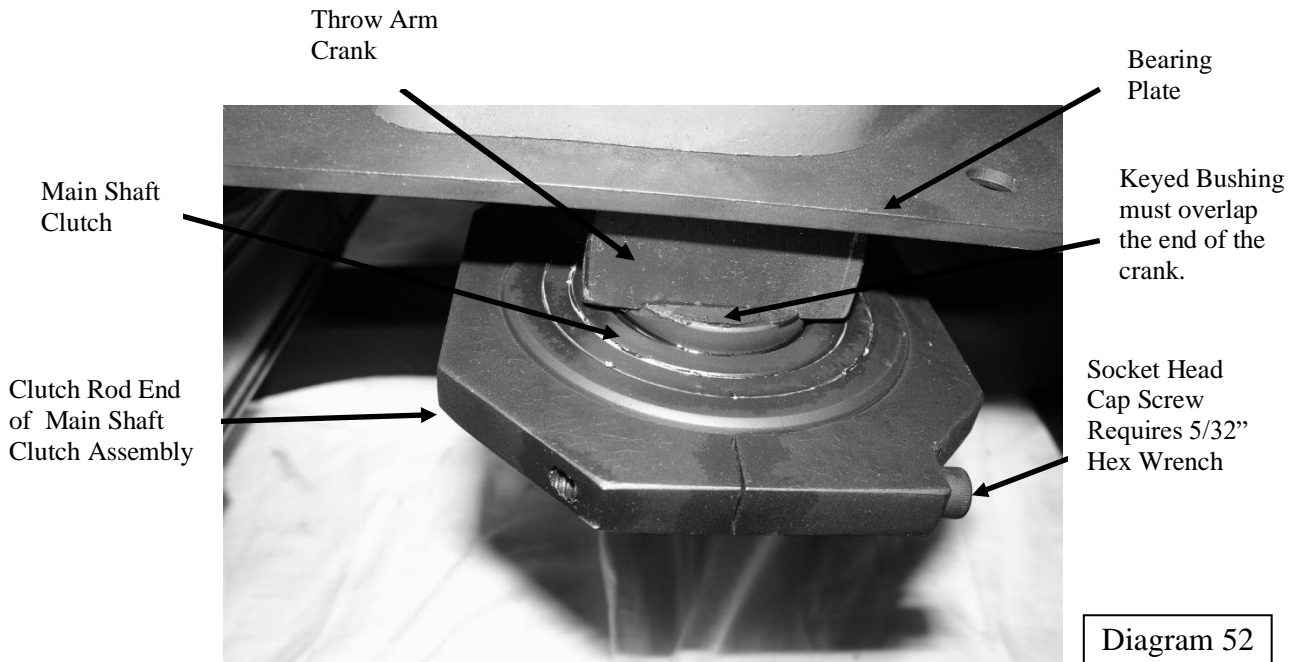

Diagram 52

### Clutch Rod End of Main Shaft Clutch Assembly



1. Back off the tension on the Main Spring crank handle by rotating it counter clockwise.
2. Turn the machine on to cock the throw arm.
3. When the throw arm stops at the throw arm brake, turn the machine off without releasing the throw arm.
4. **WHEN THE THROW ARM IS COCKED, BE SURE TO STAND BEHIND THE PAT-TRAP® AND STAY CLEAR OF THE THROW ARM.** To completely release the main spring tension on the throw arm carefully, manually, release the throw arm by first looping a rope or cord around the end of the throw arm. Then, holding back on the rope at 90 degrees to the throw arm, slowly move the throw arm past the brake and guide it around to the front of the machine.
5. Move the throw arm so that it is 6 7/8" from the right hand corner of the throw plate. (Diagram 53.)



Diagram 53

**Positioning Throw Arm When Installing Main Shaft Clutch Assembly**

6. Clamp a vise-grip onto the throw plate with the throw arm at 6 7/8" to prevent the throw arm from moving forward. See Diagram 54.

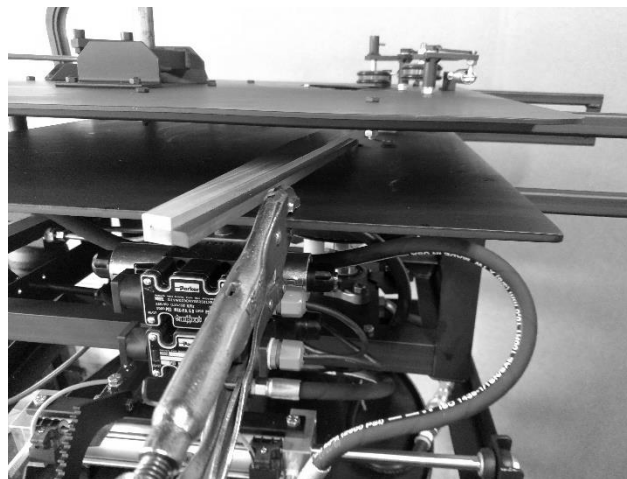
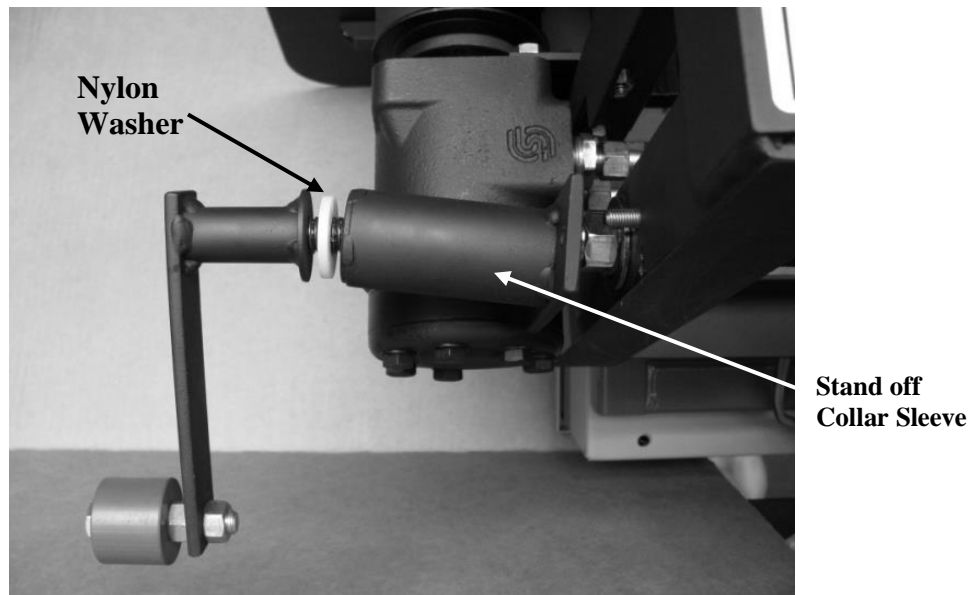

Diagram 54

**Securing the Position of the Throw Arm at 6-7/8\"/>**



7. Remove the main spring crank handle from the threaded rod by rotating it counter clockwise.



**Backing off the tension on PAT-TRAP® Main Spring Crank Handle**

8. Remove the nylon washer that is sandwiched between the crank handle and the stand off collar sleeve (See Diagram 55).
9. Remove the two (2) 1/4" bolts from the stand off collar sleeve (See Diagram 56)

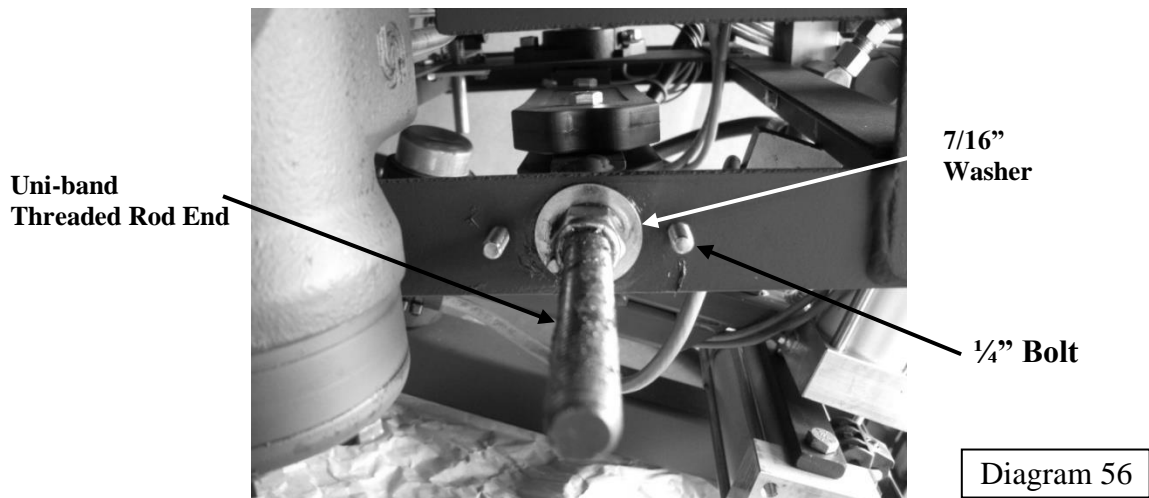

**Removing Main Spring Standoff Collar Sleeve**

10. Remove the stand off collar sleeve (See Diagram 55).



11. Locate the elastic lock-nut. Use a 3/4" wrench to remove this nut (See Diagram 57).

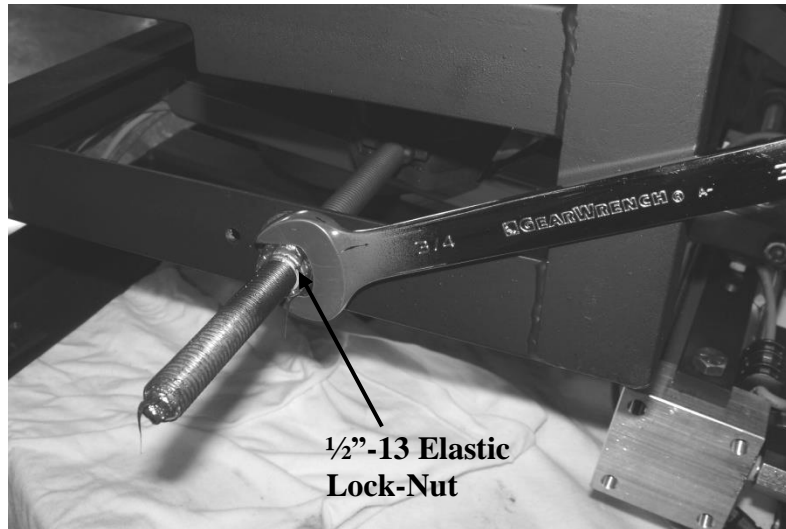

Diagram 57

**Adjusting Elastic Lock Nut with 3/4" Wrench**

12. One can now loosen the set screw (5/32" Hex Wrench) on the clutch rod-end of the Uni-Band. Pull back and down on the rod end to remove it from the clutch. (See Diagram 59).

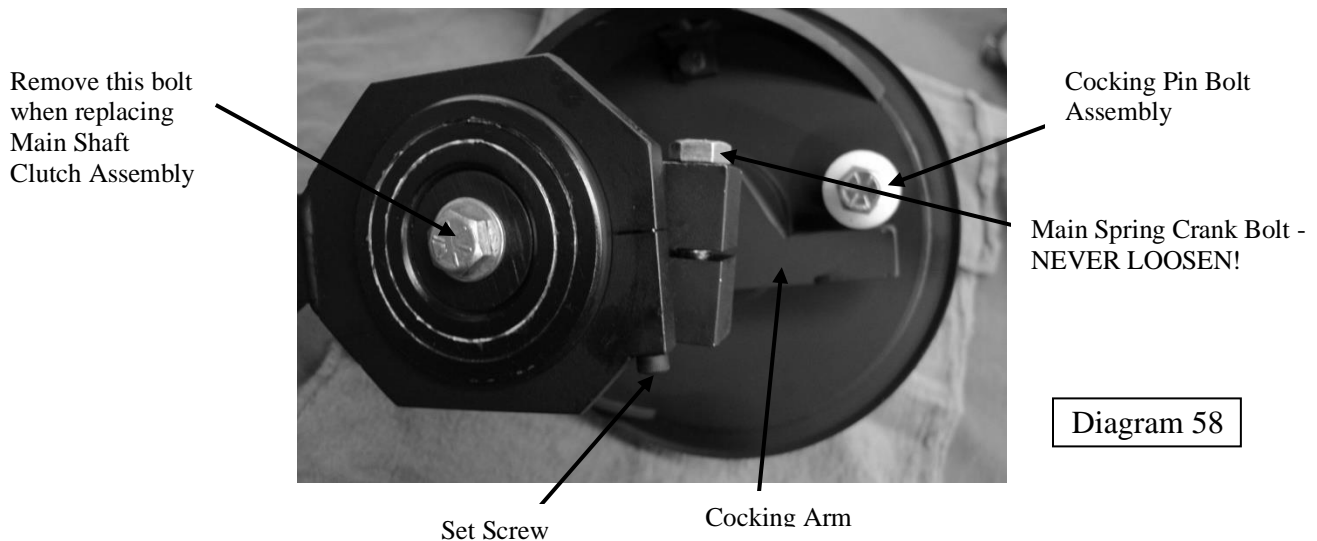

Diagram 58

**Main Shaft Clutch Assembly Connection to Throw Arm Crank**

13. Remove the old main shaft clutch assembly from the machine.

14. To reassemble put the threaded rod-end through the hole in the frame, and then pull the rod-end onto the clutch. Refer to Diagram 61 for proper positioning of the clutch within the rod-end (note 1/16" gap). Tighten up the rod-end to the clutch using a 5/32" hex head wrench, while keeping the rod-end level to the clutch.



15. Put the 7/16" washer onto threaded rod-end. Then screw on the elastic lock-nut. Refer to "Setting Distance and Speed" page 19. Regarding spring tension and adjustment of the elastic lock-nut.
16. Remove Vise Grip for the Throw Plate.
17. Once the proper distance and speed have been set, re-attach the crank handle, stand-off collar and the crank handle.
18. Inspect the hydraulic hoses to make sure that the rod-end does not rub against them.

**WARNING:** Do not work on the hoses when the throw arm is cocked. The throw arm must be released and the machine turned off when performing any work on the Pat-Trap®.

### **CHANGING A PAIR OF UNI-BANDS ON A MAIN SHAFT CLUTCH SYSTEM**

1. Let off the crank handle tension.
2. Turn the machine on to cock the throw arm.
3. When the throw arm stops at the throw arm brake, turn the machine off without releasing the throw arm.
4. **WHEN THE THROW ARM IS COCKED, BE SURE TO STAND BEHIND THE TRAP AND STAY CLEAR OF THE THROW ARM.** To completely release the tension on the throw arm carefully, manually, release the throw arm by first looping a rope or cord around the end of the throw arm. Then, holding back on the rope at 90 degrees to the throw arm, slowly move the throw arm past the brake and guide it around to the front of the machine.
5. Move the throw arm so that it is 6 7/8" from the right hand corner of the throw plate. See Diagram 53.
6. Clamp a vise-grip onto the throw plate with the throw arm at 6 7/8" to prevent the throw arm from moving forward. See Diagram 54.
7. Do not loosen the throw arm crank bolt. Diagram 43.
8. Changing the Uni-Bands can be done without removing the threaded rod-end from the machine.



9. Loosen the Uni-Band connecting bolts; no not remove yet. Disconnect the rod-end from the clutch by loosening the rod-end bolt using a 5/32” hex head wrench. Pull down on the rod-end to remove; if it’s tight, use a screwdriver to pry down on it. Now remove the uni-band connecting bolts from the threaded rod-end and remove the bands from the machine. Then remove the clutch rod -end from the uni-bands. See Diagrams 60, 61 and 62
10. When re-assembling, connect the new bands to the clutch rod-end and hand tighten while keeping the parts straight to one another. Now connect to the threaded rod-end and hand tighten the connecting bolt. Pull the clutch rod-end back onto the clutch using a rubber hammer to tap it on. If you can’t pull it back on to the clutch, because of too much tension, then loosen the nylon nut on the crank handle end to create slack. Refer to Diagram 61 for proper positioning of the clutch within the rod-end (note 1/16” gap). Tighten the clutch rod-end bolt using a 5/32” hex head wrench. Keep the rod-end level on the clutch and in line with the bands and the threaded rod-end. Refer to Diagram 60 for right side up.

Align the Uni-Bands as follows: See diagrams 60, 61 and 62

- A. Keep the clamp in front of the throw arm at 6 7/8” (Step 2)
  - B. Tension the Uni-Bands with ten turns of the crank handle. This will pull the rod-end s and uni-bands in line with one another.
  - C. Use two 9/16” wrenches. Hold back on the bolt head (on top) while tightening the nut (on bottom)
  - D. Put equal pressure on both of the wrenches and torque the bolts to 25 ft/lbs minimum – 40 ft/lbs maximum. If using the sprocket toothed washers torque to 25 lbs. “Sprocket toothed washer must be used if the area around the holes is not indented.”
11. Remove the vise grip from the throw plate.
  12. Refer to the section on *Setting Distance and Speed (page 19)*, regarding minimum spring tension and adjustment of the elastic lock-nut.
  13. Begin normal operation of the machine.





### ASSEMBLY/INSTALLATION OF THE UNI-BAND (Main Spring) to the MAIN SHAFT CLUTCH

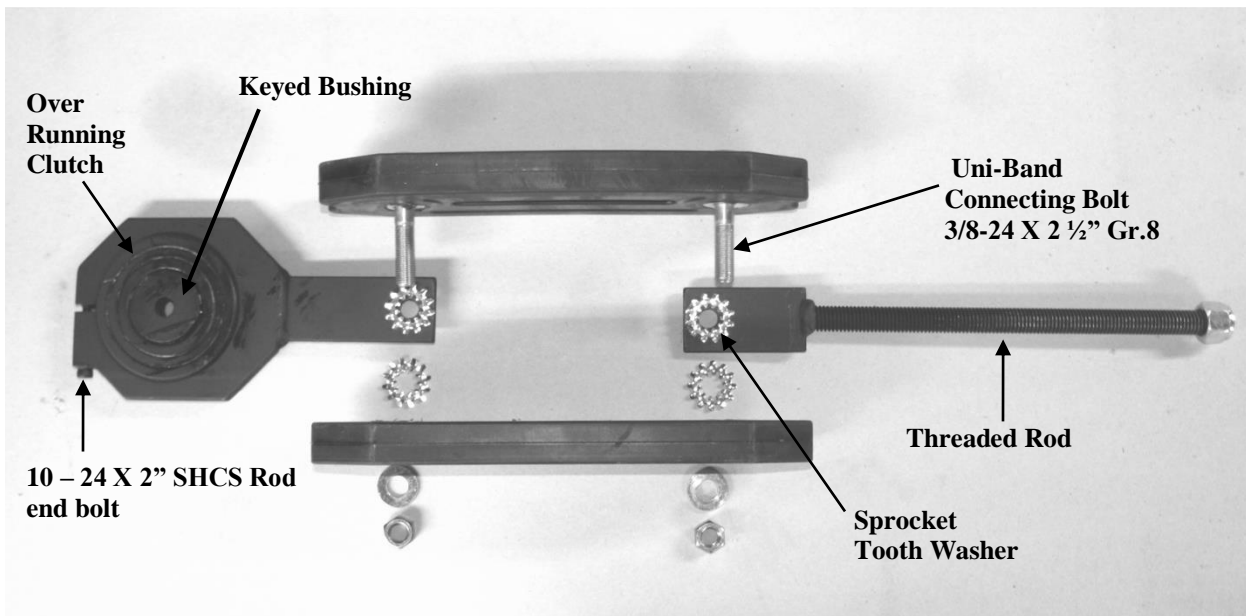
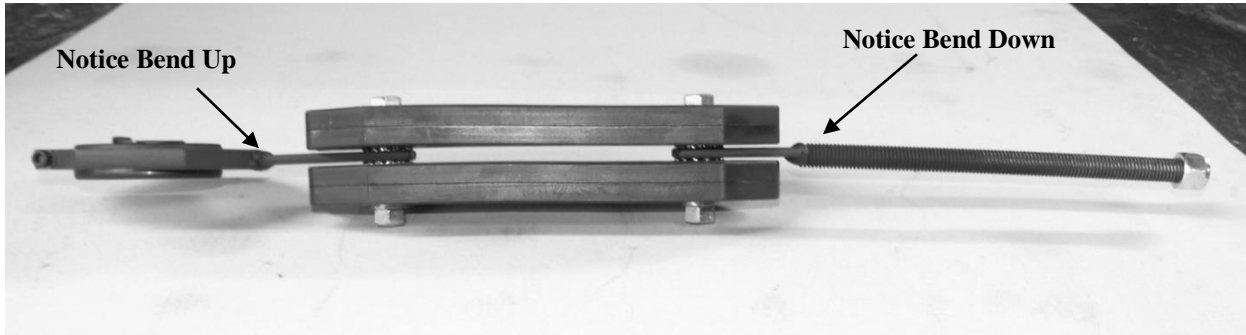

Diagram 60



**PAT-TRAP, Inc.**

**\*Choice of the ATA\***

632 Western Avenue • Henniker, New Hampshire 03242 • Tel. (603) 428-3396

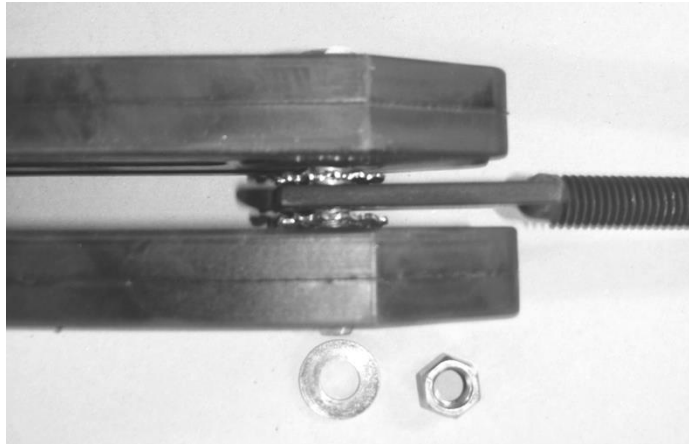
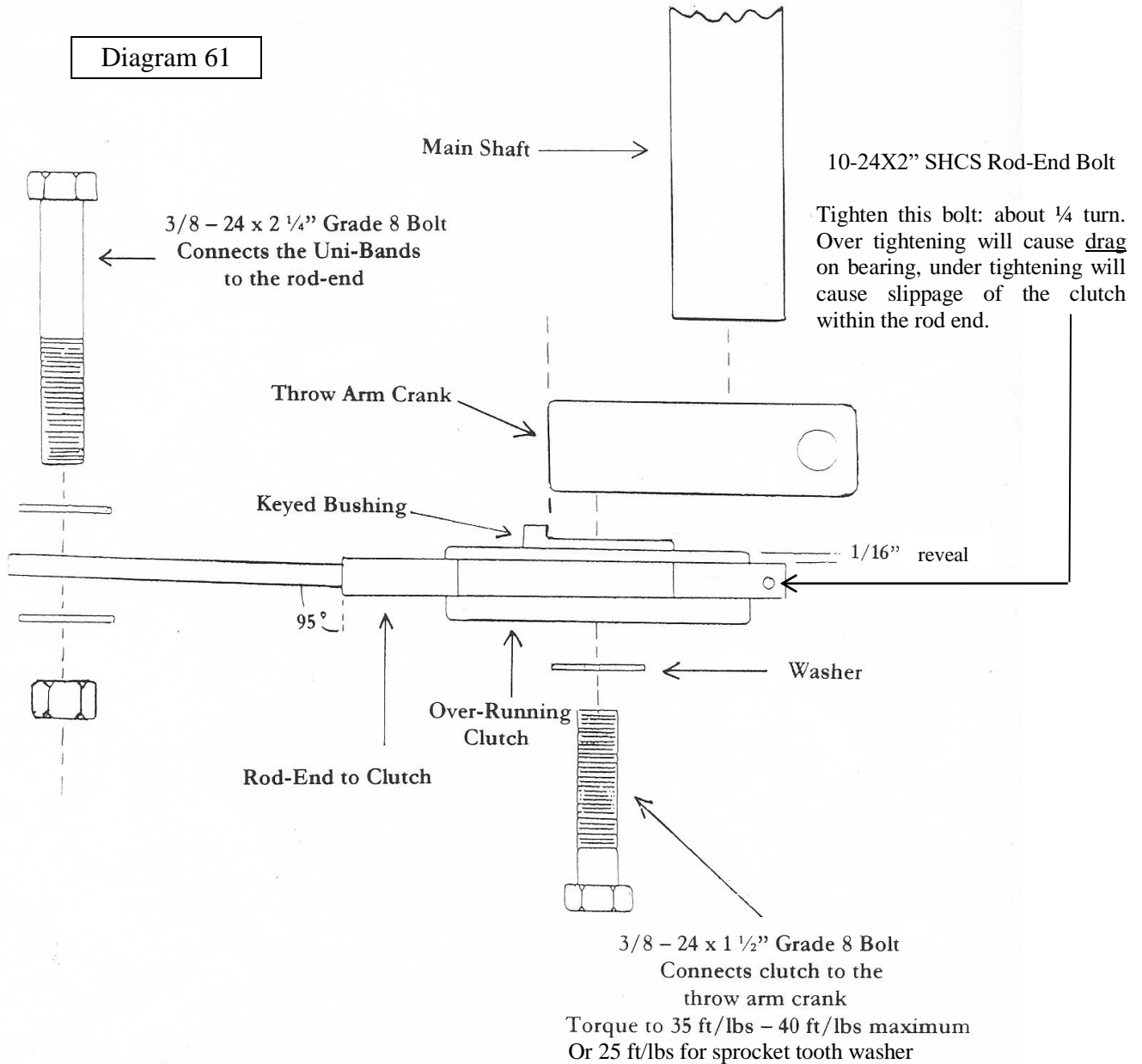



Diagram 61



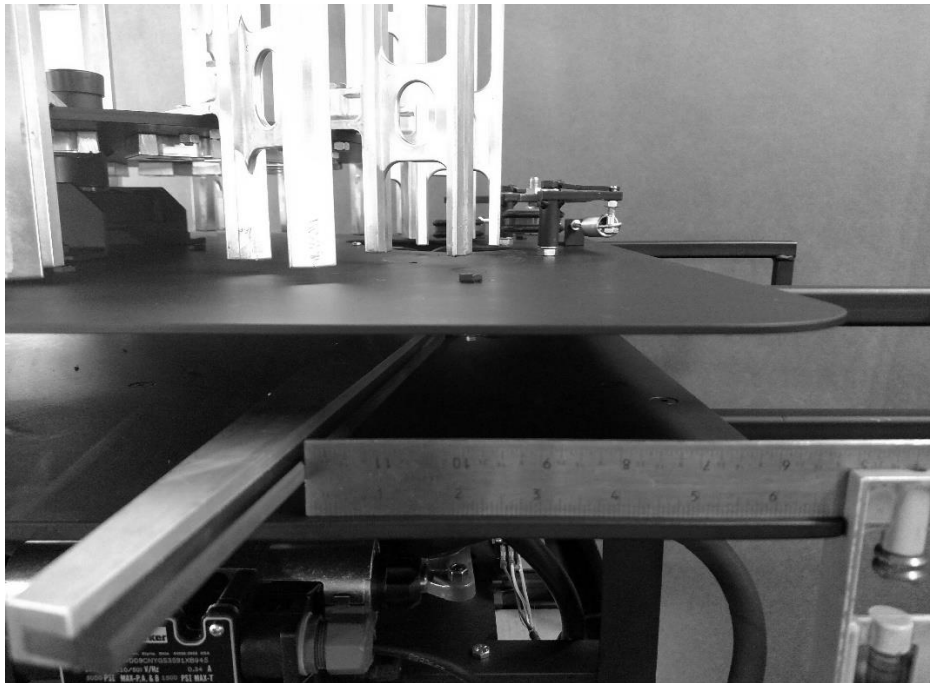

Diagram 61

Throw arm crank location at the bottom of the throw arm shaft.



Diagram 62

**DO NOT LOOSEN or REMOVE** unless repairing or replacing. Contact Pat-Trap for instructions.



## REPLACEMENT OF THE ELEVATOR EXTENSION SPRING

\*\*\*IMPORTANT: Do not loosen or remove either the lock screw that the bottom of the spring hooks onto or the set screw. The screw is holding the bearing block in position so that the bearing is in alignment with the cam – See Diagram 64.

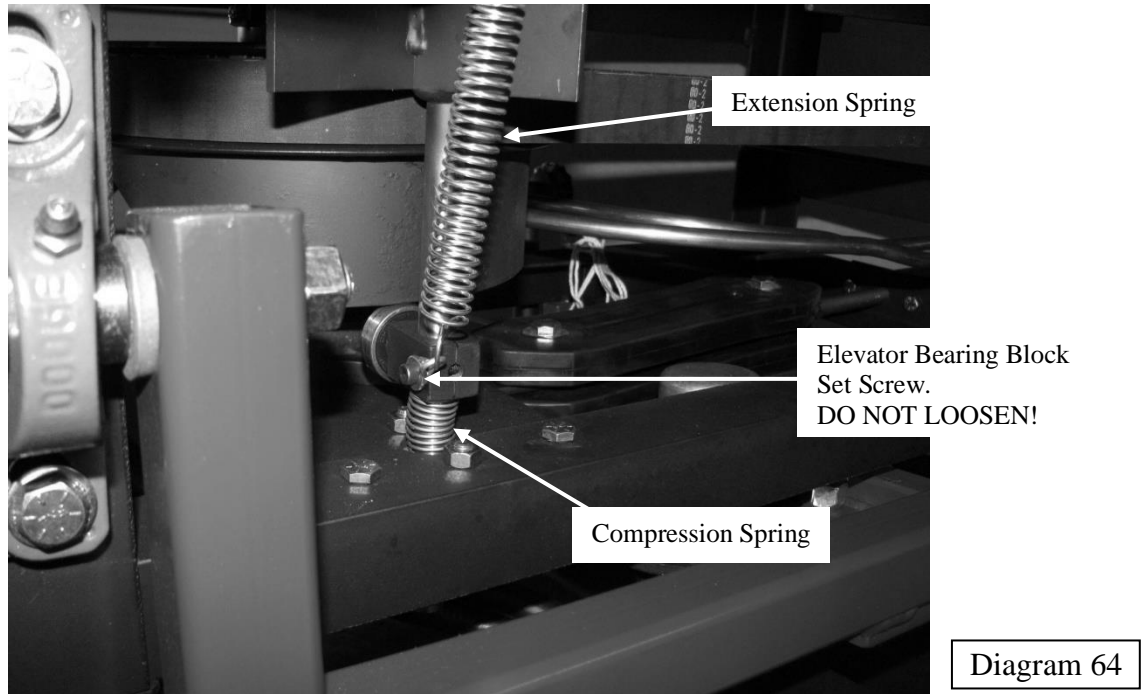

### Elevator Bearing Block Detailing Bearing on Cam

1. Turn the machine on.
2. Fire the throw arm and then turn the machine off as soon as the elevator goes up: When the cam leaves the cam bearing.
3. If disconnecting the spring, remove the top end first.
4. If connecting the spring, connect the bottom end first.

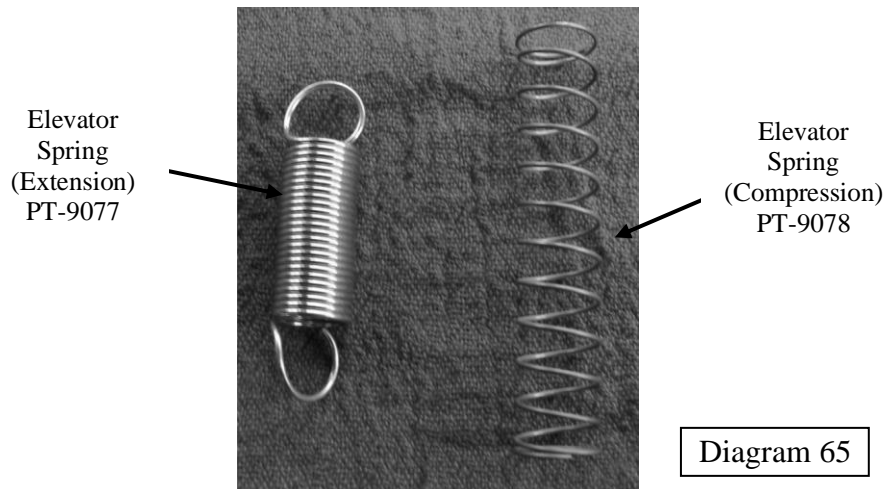



## REPLACEMENT OF THE ELEVATOR COMPRESSION SPRING

1. Turn the machine on. As soon as the elevator goes up, turn the machine off.
2. Remove the two elevator rod guide bolts (7/16" wrench). See Diagram 66.

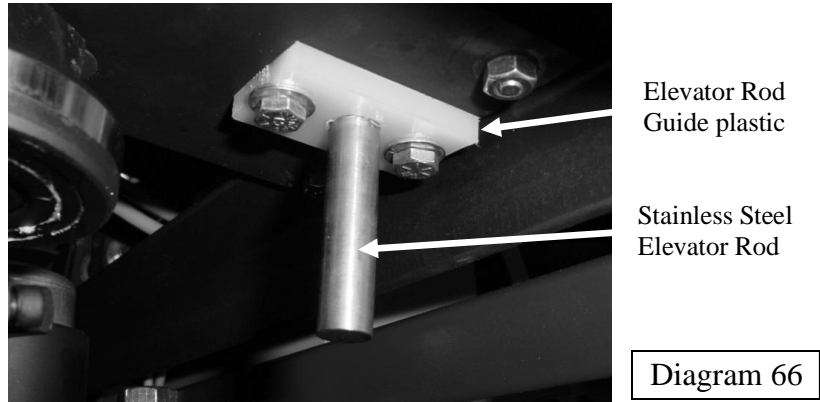

### Elevator Rod Guide

3. Remove the ELEVATOR ROD GUIDE. The plastic elevator rods guide must be replaced the same way as it was found (i.e., do not flip over).
4. Put the compression spring on over the elevator rod.
5. Replace the Elevator Rod Guide.
6. Fasten the two bolts only slightly snug; over tightening will deform the material and possibly cause the guide to tighten against the elevator rod.



## ELEVATOR GUIDES and ELEVATOR ROD GUIDE

The elevator needs to be inspected annually. If the guides become worn they can cause the elevator to have too much free play. The guides need to be replaced before the elevator extends above the surface of the throw plate. See picture #2.

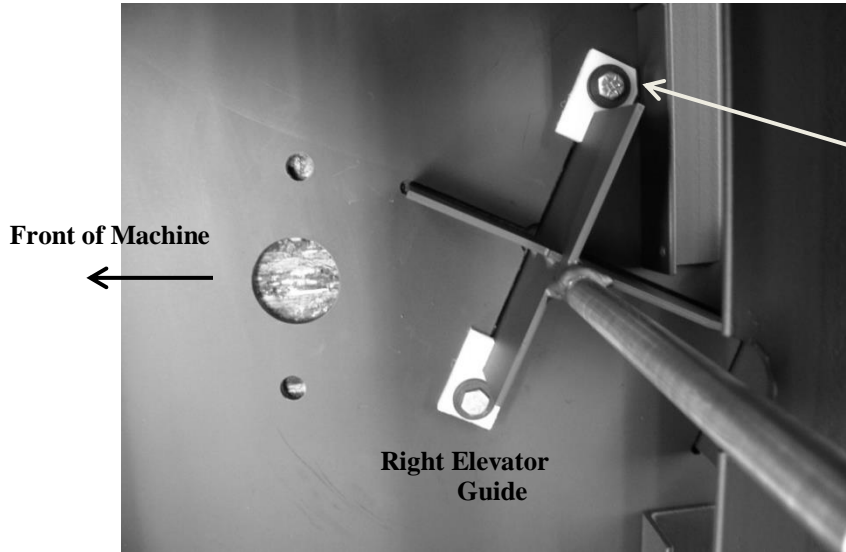

Picture #1  
Left Guide with beveled edge towards angle iron frame.

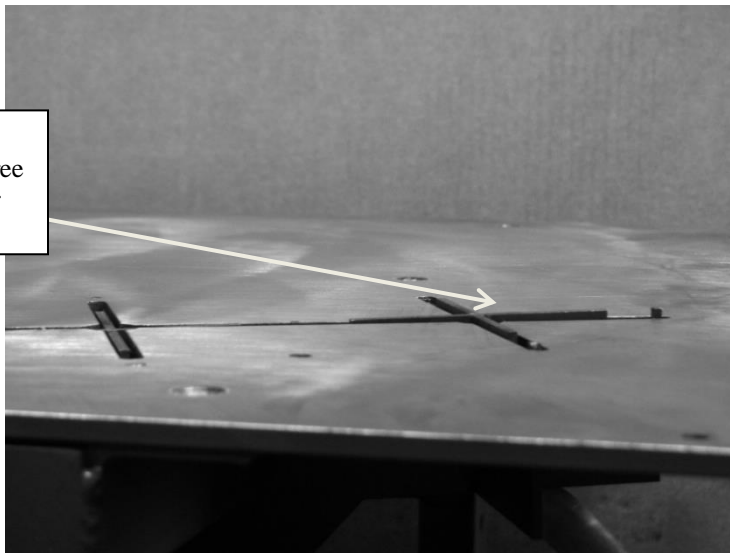

Picture #2  
Elevator has too much free play. Replace Elevator Guides & Rod Guide



## THROW ARM SHAFT BEARING MAINTENANCE

Grease both the Upper and Lower Flange Bearings that Support the Main Shaft (throw arm) and Main Gear Belt Pulley Wheel once a year with a **PREMIUM** grade lubricating grease such as Lithium or Mobil EP1. Heavier-weight grease will “gum-up” and not allow the throw arm shaft to rotate freely. Diagram 67.

**Grease  
Fittings**

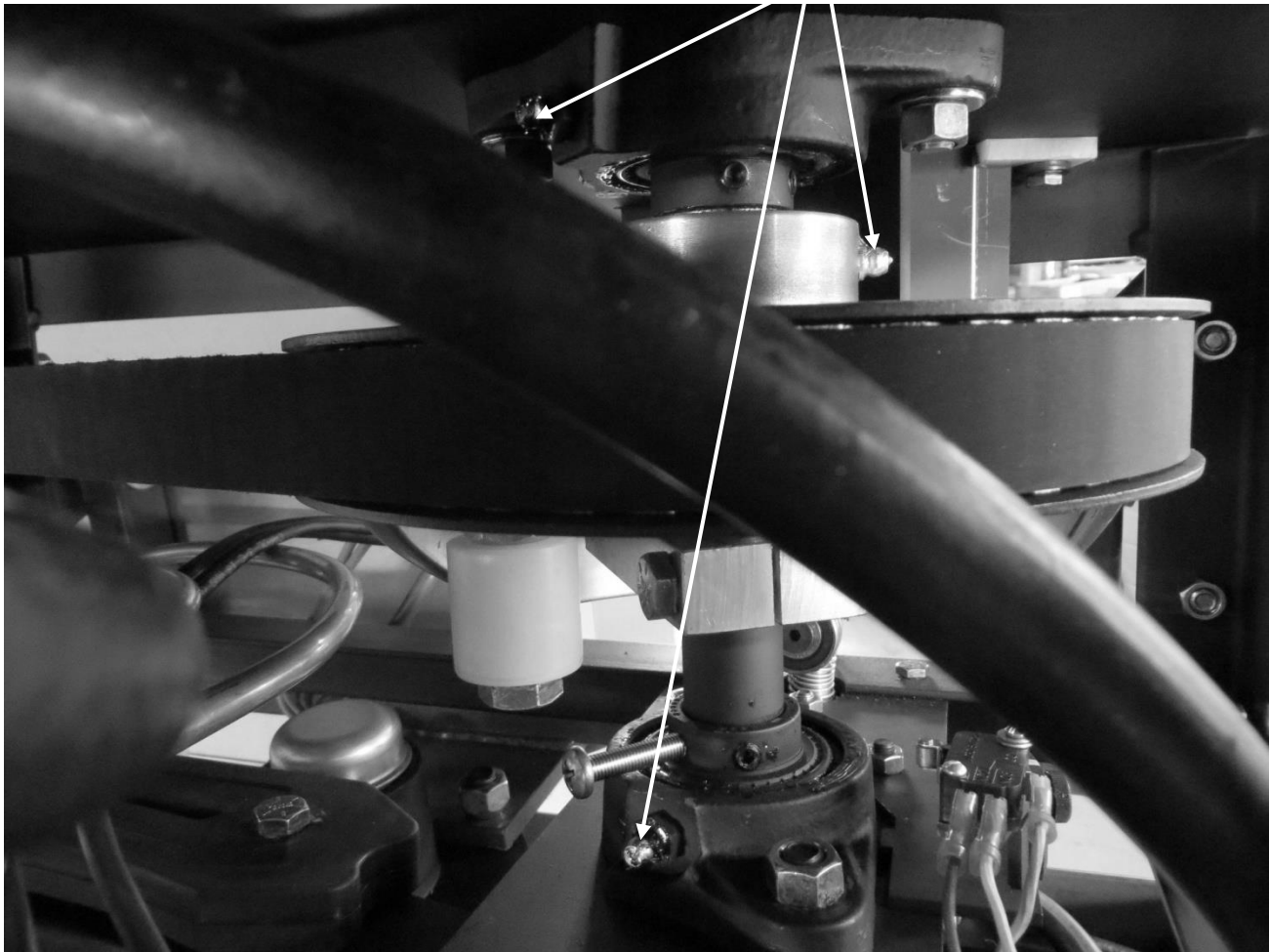

**Throw Arm Drive Shaft Assembly**

Diagram 67





**HYDRAULIC VALVE IDENTIFICATION – STANDARD PAT-TRAP®**

The top valve on a standard PAT-TRAP® machine is a “soft shift” valve, and it controls the oscillation hydraulic cylinder. Diagram 68.

The lower valve on a standard PAT-TRAP® machine is a “single solenoid” hard shift valve, and it controls the hydraulic motor which cocks the throw arm and advances the turret. It is not a “soft shift” valve.

Single Solenoid Valve  
PT-9060  
(Throw Arm)

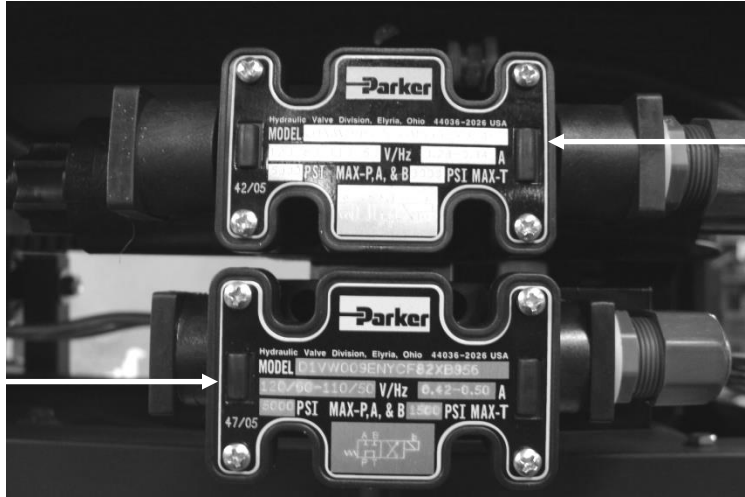

Soft Shift Valve  
PT-9061  
(Oscillation)

Diagram 68

**Hydraulic Valves on Standard PAT-TRAP®**



**HYDRAULIC VALVE IDENTIFICATION – WOBBLE PAT-TRAP®**

The top valve on a PAT-TRAP® Wobble machine is a “soft shift” valve, and it controls the horizontal oscillation hydraulic cylinder. Diagram 69

The middle valve on a PAT-TRAP® Wobble machine is a “single solenoid” hard shift valve, and it controls the hydraulic motor which cocks the throw arm and advances the turret. It is not a “soft shift” valve.

The bottom valve on a PAT-TRAP® Wobble machine is a “soft shift” valve, and it controls the vertical “wobble” hydraulic cylinder. Diagram 69.

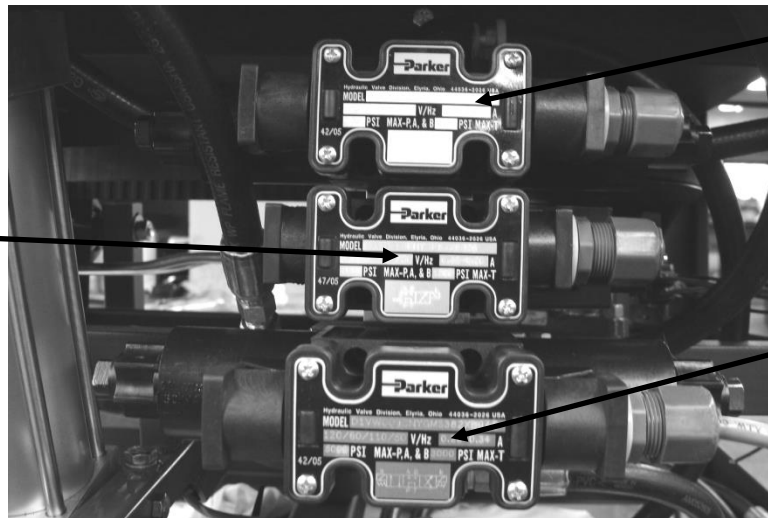

Single Solenoid Valve  
PT-9060  
(Throw Arm)

Soft Shift Valve  
PT-9061  
(Oscillation)

Soft Shift Valve  
PT-9061  
(Wobble)

Diagram 69

**Hydraulic Valves on PAT-TRAP® Wobble**

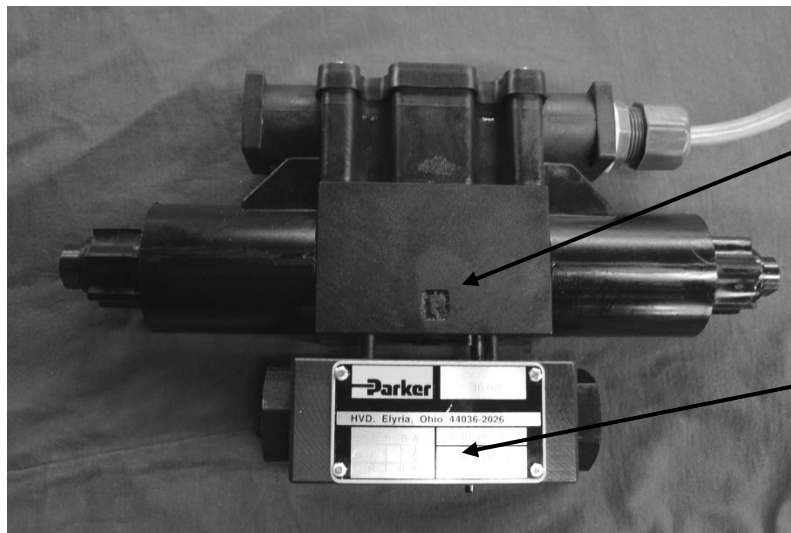

Soft Shift Valve  
PT-9061  
(Wobble)

Check Valve  
Wobble Only  
PT-9062

Diagram 70

**Wobble Soft Shift Valve shown with Check Valve**



## SOFT SHIFT VALVE WIRING GUIDE (OSCILLATION/WOBBLE VALVES)

NEVER STAND IN FRONT OF A TRAP MACHINE. THE TRAP MACHINE MUST BE TURNED OFF AND THE SPRING RELEASED BEFORE ENTERING THE TRAP HOUSE. NEVER ATTEMPT TO MAKE ANY ADJUSTMENT WHILE THE THROW ARM IS COCKED.

The wiring guide for the Soft Shift Valve on a PAT-TRAP® is as pictured in Diagram 71 below:

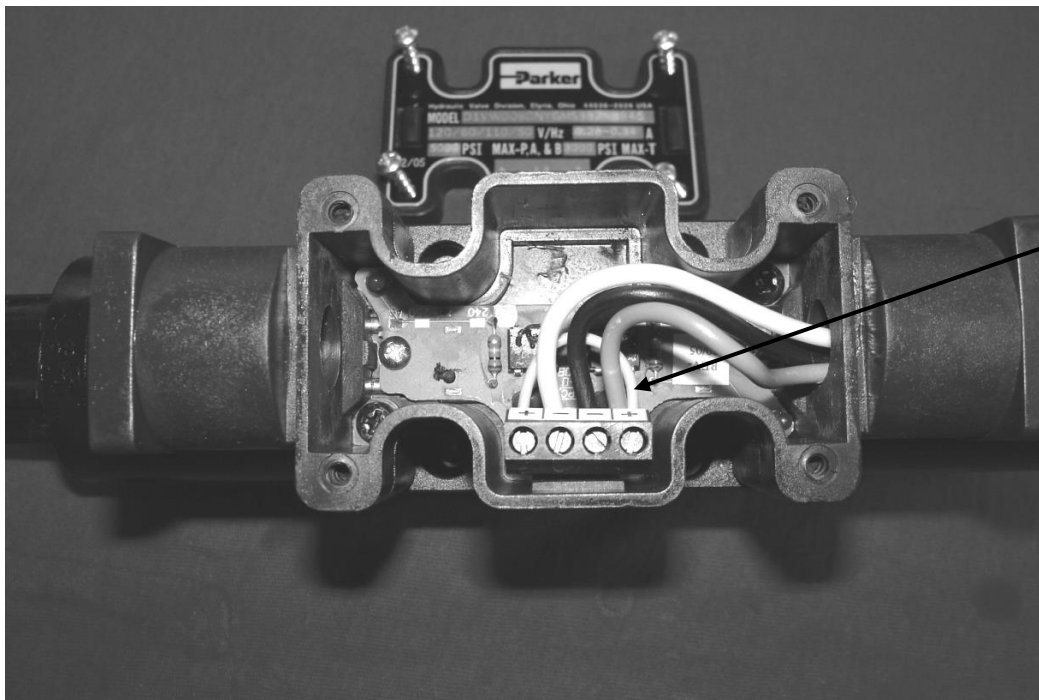

Diagram 71

### Wiring of Soft Shift Valve

Wiring Terminals from Left to Right:

- Jumper Wire (+)
- White Wire (-)
- Black Wire (-)
- Green Wire and Jumper Wire (+)



## SINGLE SOLENOID VALVE (THROW ARM/TURRET) WIRING GUIDE

NEVER STAND IN FRONT OF A TRAP MACHINE. THE TRAP MACHINE MUST BE TURNED OFF AND THE SPRING RELEASED BEFORE ENTERING THE TRAP HOUSE. NEVER ATTEMPT TO MAKE ANY ADJUSTMENT WHILE THE THROW ARM IS COCKED.

The wiring guide for wiring the Single Solenoid Valve on a PAT-TRAP® is as pictured in Diagram 72 below:

Diagram 72

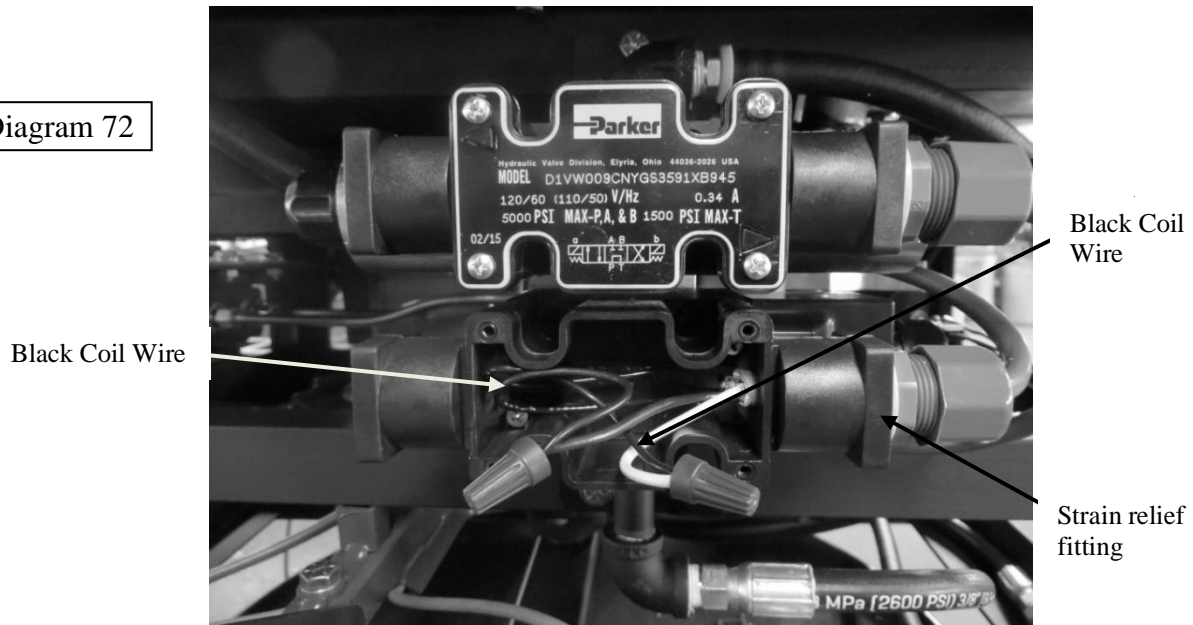

### Wiring of Single Solenoid Valve

Connect one of the valve's black coil wires to each of the black and white wires entering the strain relief fitting along with a leg from the Varistor as shown above.



## REPLACEMENT OF A HYDRAULIC VALVE

1. NEVER STAND IN FRONT OF A TRAP MACHINE. THE TRAP MACHINE MUST BE TURNED OFF AND THE SPRING RELEASED **BEFORE** ENTERING THE TRAP HOUSE. NEVER ATTEMPT TO MAKE ANY ADJUSTMENT WHILE THE THROW ARM IS COCKED.
2. Disconnect the PAT-TRAP® from its power source.
3. Disconnect the Return Line Hose from the pump unit.
4. Remove the cover plate on the valve's terminal box as shown in Diagram's 71 & 72.
5. Disconnect the electrical wires that are located within the valve's terminal box and remove from the strain relief fitting located on the side of the valve.
6. Place a paper towel or rag below the valve to be removed.
7. Remove the old hydraulic valve from the hydraulic sub-plate manifold by removing the four bolts that hold it in place. A 5/32" T-Handled Hex Wrench works best as shown in Diagram 73. Make sure that the holes are cleaned out before using the wrench.



Diagram 73

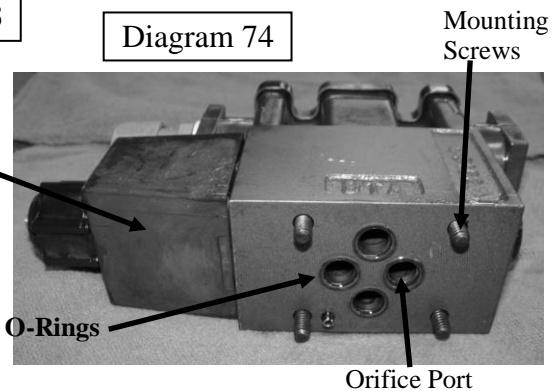

Diagram 74

### Loosening/Tightening Valve Mounting Screws

### Rear View of Single Solenoid Valve

8. Replace the old valve with the proper replacement valve, and secure to the hydraulic sub-plate manifold with the four bolts that hold it in place. A 5/32" T-Handled Hex Wrench works best as shown in Diagram 73.
9. Note: Use caution that the four O-Rings located around the valve's orifice ports are securely in place or else a leak will occur. See Diagram 74.
10. Re-attach the wires that are located within the valve's terminal box after feeding them through the strain relief fitting located on the side of the valve. Refer to Diagram 71 or 72 for the proper valve wiring guide.
11. Reconnect the Return Line Hose from the pump unit.
12. Re-attach the cover plate on the Valve's Terminal Box as shown in Diagram's 71 or 72.
13. Connect the PAT-TRAP® back to its power source and resume operation.



**To replace a FIELD ANGLE LIMIT SWITCH use the following directions:**

1. NEVER STAND IN FRONT OF A TRAP MACHINE. THE TRAP MACHINE MUST BE TURNED OFF AND THE SPRING RELEASED BEFORE ENTERING THE TRAP HOUSE. NEVER ATTEMPT TO MAKE ANY ADJUSTMENT WHILE THE THROW ARM IS COCKED.
2. Disconnect the PAT-TRAP® from its power source.
3. Open the cover of the Electrical Enclosure located on the back of the PAT-TRAP® with a medium Philips screwdriver .
4. Loosen the screws on the Romex Connector located on the rear exterior of the electrical enclosure. Remove the switch wires from their terminal. Tie a string to the switch wire ends and pull out of the box. Fish the new switch wire back into the box.
5. The connections for the field limit switches to their terminal shown in Diagram 76 are as follows:



**Inside the Electrical Enclosure of the PAT-TRAP®**

Diagram 76

6. After replacing the appropriate field limit switch, close and secure the cover of the electrical enclosure with 6 - 32 X1/4 Philips head screws. Connect the PAT-TRAP® back to its power source and resume operation.



**WIRING GUIDE FOR FIELD ANGLE LIMIT SWITCHES (#11,#12,#11A, & #12A)**

#12 Left Angle  
Limit Switch  
N.O. PT-9222

#11 Right Angle  
Limit Switch  
N.O. PT-9222



2-Hole Spacer Bar

Diagram 75

**PAT-TRAP® Oscillation Cylinder with Field Angle Switches and 2-Hole Spacer Bar**

“DOWN”  
Limit Switch  
#12A  
(N.O.)  
PT-9222

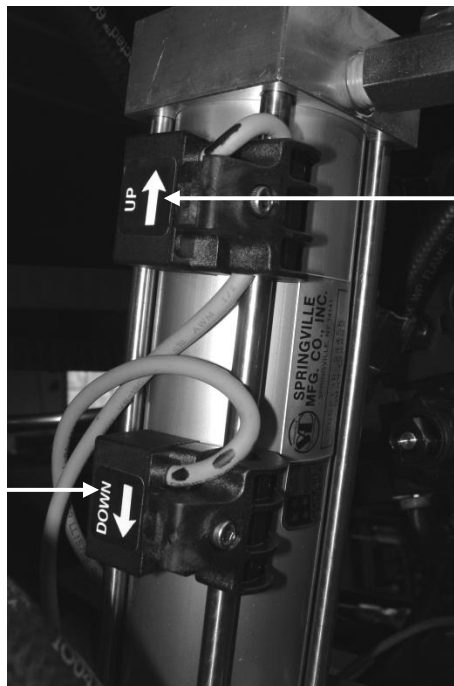

“UP”  
Limit Switch  
#11A  
(N.O.)  
PT-9222

Diagram 77

**Limit Switches on the PAT-TRAP® Wobble Hydraulic Cylinder**



## REPLACEMENT OF OSCILLATION CYLINDER

To replace a horizontal hydraulic oscillation cylinder use the following directions:

NEVER STAND IN FRONT OF A TRAP MACHINE. THE TRAP MACHINE MUST BE TURNED OFF AND THE SPRING RELEASED BEFORE ENTERING THE TRAP HOUSE. NEVER ATTEMPT TO MAKE ANY ADJUSTMENT WHILE THE THROW ARM IS COCKED.

1. Disconnect the PAT-TRAP® from its power source.
2. Tools required: 9/16" wrench (ratchet or speedy wrench will help), 9/64" hex wrench, 1/2" wrench, 5/8" and 11/16" wrenches (or adjustable wrench).
3. Remove field angle limit switches from the cylinder tie rods with a 9/64" hex wrench.
4. Loosen the two cylinder bar bolts, but do not remove yet, with a 9/16" wrench. The Cylinder Bar remains on the machine.

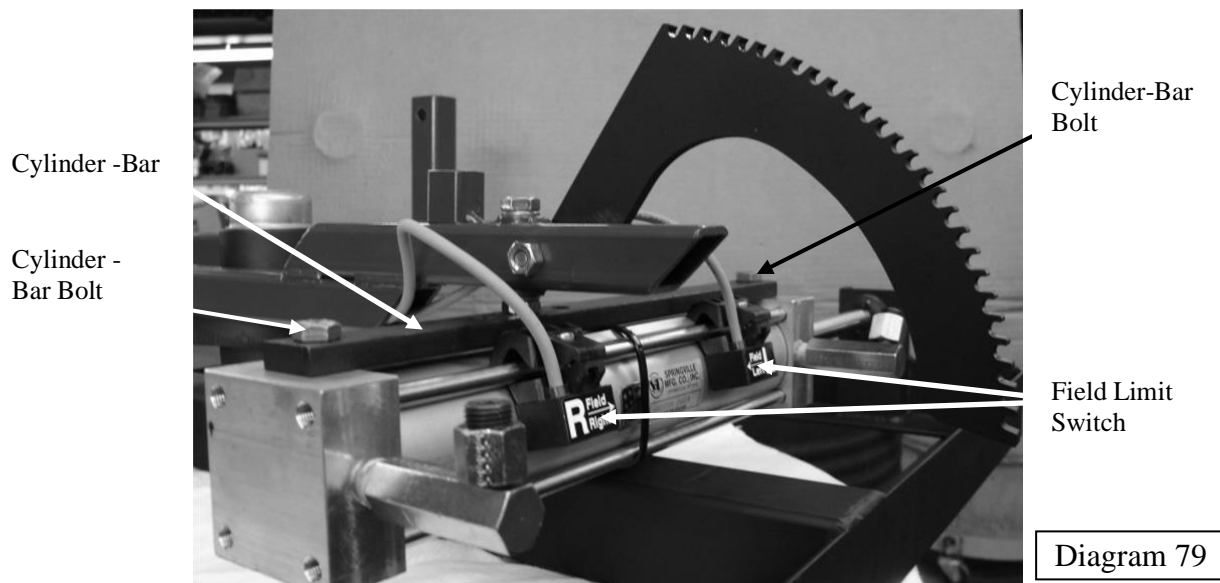

### Removing Cylinder Bar Bolts

5. Remove the cylinder rod-end bolt using a 1/2" open-end wrench on the milled Wrench flat at the end of the cylinder rod and a 9/16" wrench on the rod-end bolt. (Do not lose the bushings or bushing caps.) See Diagram 80.



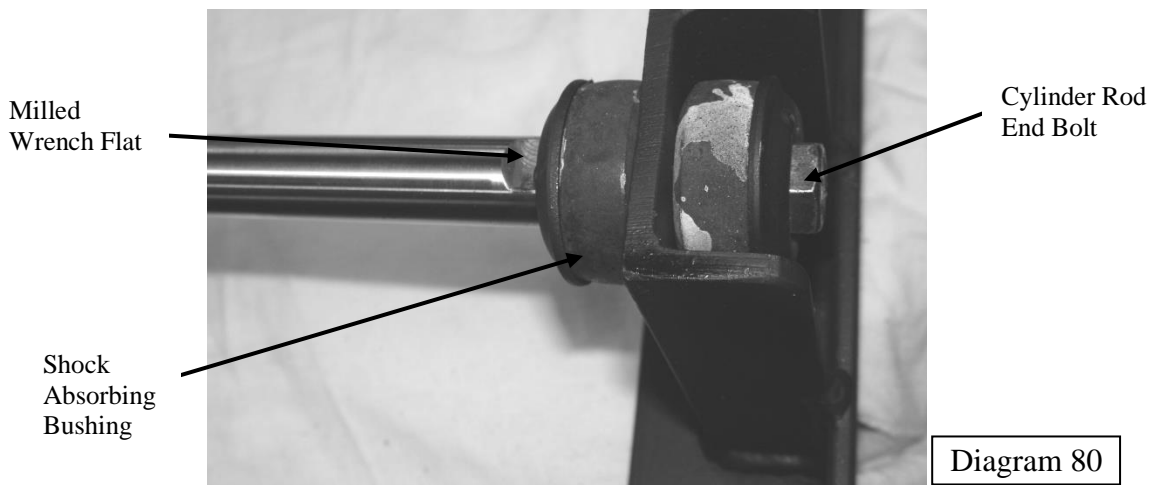

**Removing Shaft Rod- End Bolt From Frame**

6. Remove the cylinder bar bolts.
7. Now that the cylinder is free, remove the hydraulic hoses that connect to the long adapters. Use the 5/8" and 11/16" open-end wrenches to perform this task.
8. When putting on the new oscillation cylinder, first secure the cylinder to the cylinder bar with the two bolts.
9. Tighten the rod-end bolt to the cylinder rod, making sure that the bushings and bushing caps are in place.
10. Make sure that the cylinder bar bolts are tight.
11. Replace the field angle limit switch to the cylinder tie rods with the 9/64" hex wrench. Do not over tighten the plastic switch bracket clamp because it WILL break.
12. Connect the hoses. When tightening, make sure that the hoses are turned slightly away from the frame of the machine. This is done so that the hoses won't rub against the machine when at the extreme left and right angle limits.
13. After installing the new cylinder, turn on the machine.
14. Put the Auto/Manual switch into the manual position. Push the left button and run the cylinder to the end.
15. Push the right button and run the cylinder to the end. Now the air is out of the cylinder.
16. Check the oil level within the hydraulic pump reservoir and add **5W-20 motor oil** as required.
17. Move the cylinder back to center and begin normal operation.



## REPLACEMENT OF WOBBLE CYLINDER

To replace a vertical hydraulic Wobble cylinder use the following directions:

1. Tools required: 1" thick block of wood, 9/16" wrench (ratchet or speedy wrench will help), 9/64" hex wrench, 1/2" wrench, 5/8" and 11/16" wrenches (or adjustable wrench).
2. Set the 1" thick block of wood on the frame post. See Diagram 81.
3. Carefully lower the machine onto the block of wood without crushing it.

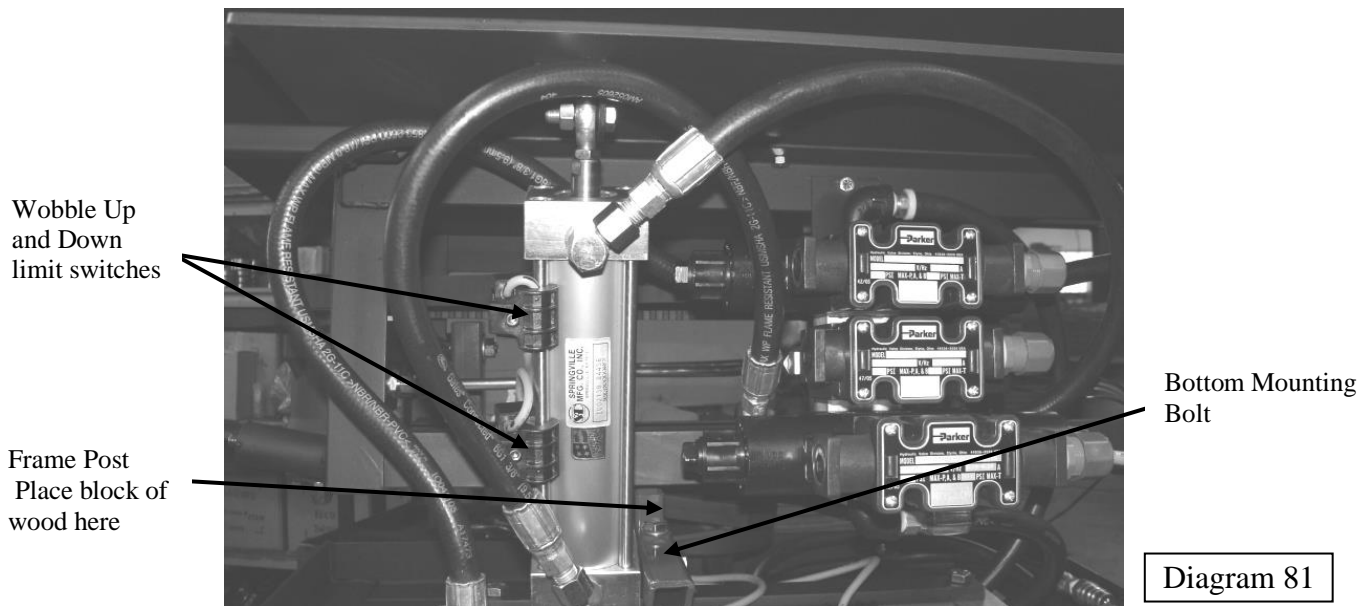

### Wobble Cylinder

4. STAND BEHIND THE PAT-TRAP<sup>®</sup> MACHINE RELEASE THE THROW ARM AND TURN OFF THE MACHINE. THE TRAP MACHINE MUST BE TURNED OFF AND THE SPRING RELEASED BEFORE ENTERING THE TRAP HOUSE. NEVER ATTEMPT TO MAKE ANY ADJUSTMENT WHEN THE THROW ARM IS COCKED.
5. Disconnect the PAT-TRAP<sup>®</sup> from its power source.
6. Remove Wobble Up and Down limit switches from the cylinder tie rods with a 9/64" hex wrench. See Diagram 81.
7. Remove the cylinder rod-end mounting bolt using two 9/16" open-end wrenches. See Diagram 82.

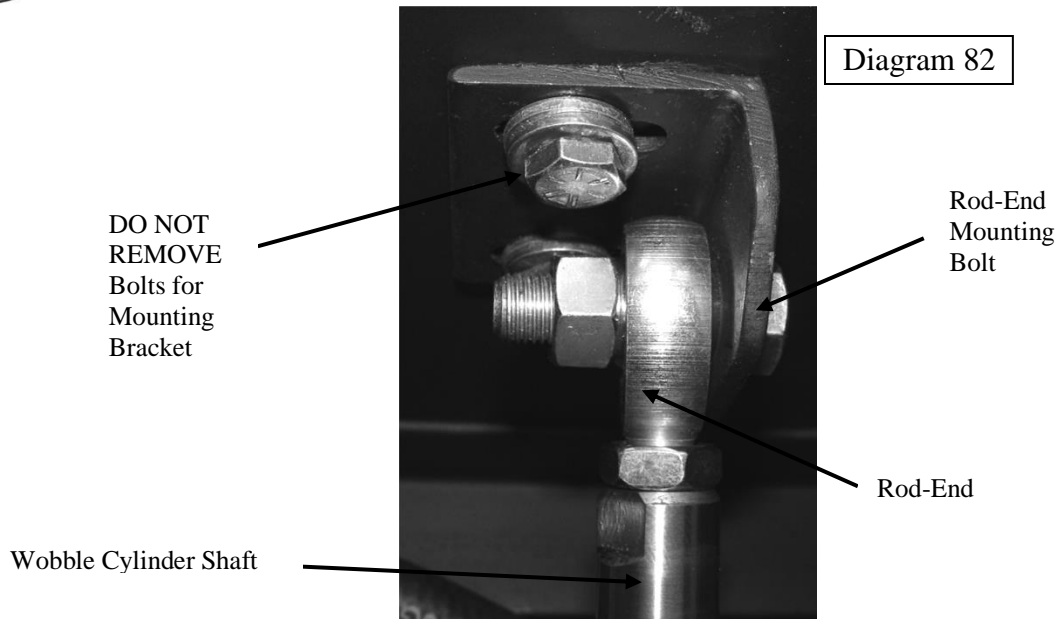

**Rod End to Mount Wobble Cylinder to PAT-TRAP®**

8. Remove the hydraulic hoses that connect to the short adapters. Use the 5/8" and 11/16" open-end wrenches to perform this task.
9. Remove the bottom mounting bolt located on the bottom of the Wobble Cylinder using a 1/2" wrench. See Diagram 81.
10. When putting on the new Wobble cylinder, first apply a small quantity of Locktite 680 to the last threads of the #5/16-18 x 1-3/4" bottom mounting bolt as shown in Diagram 82.

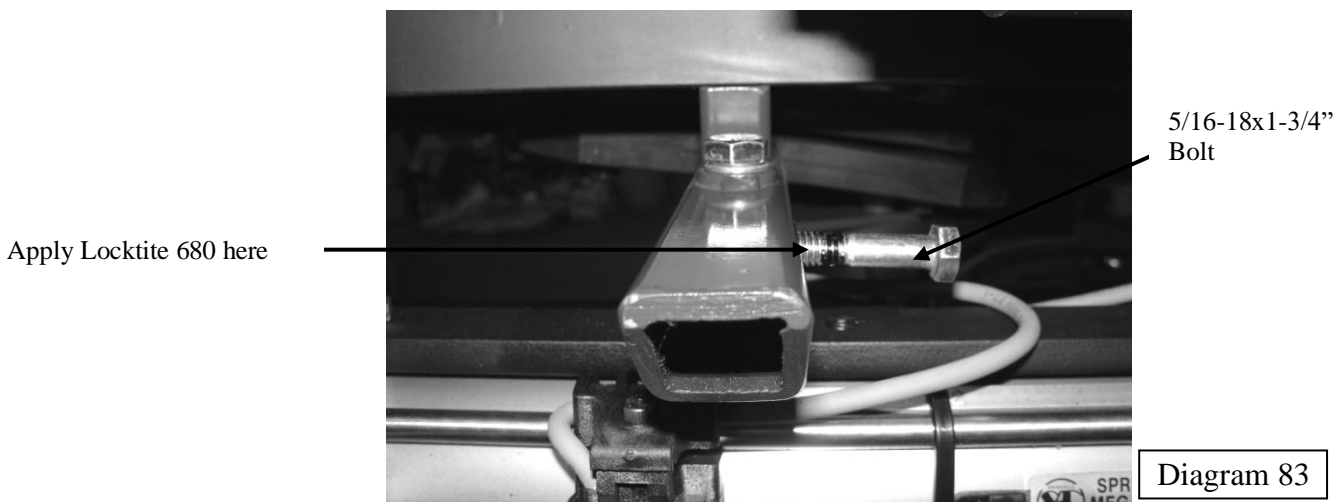

**Bolt for to Mount Wobble Cylinder**



11. Replace the cylinder rod-end mounting bolt using two 9/16" open-end wrenches. Diagram 82.
12. Remove 1" thick block of wood from frame post.
13. Make sure that the cylinder rod-end mounting bolt is tight (torque to 25-30 ft-lbs).
14. Replace the field angle limit switch to the Wobble cylinder tie rods with the 9/64" hex wrench. Do not over-tighten the plastic switch bracket clamp because it WILL break.
15. Connect the hoses. When tightening, make sure that the hoses are positioned as shown in Diagram 81. This is done so that the hoses won't rub against the machine when at the extreme up, down, left, and right angle limits.
16. After installing the new Wobble cylinder, turn on the machine.
17. Put the Auto/Manual switch into the manual position. Push the UP button and run the cylinder rod to the end. Remove the wooden block.
18. Push the DOWN button and run the cylinder rod to the end. Now the air is out of the cylinder.
19. Check the oil level within the hydraulic pump reservoir and add 5W-20 oil as required.
20. Move the Wobble cylinder back to center (between limit switches) and begin normal operation.



## **General Maintenance**

**IMPORTANT: NEVER STAND IN FRONT OF A TRAP MACHINE. THE TRAP MACHINE MUST BE TURNED OFF AND THE SPRING RELEASED BEFORE ENTERING THE TRAP HOUSE. NEVER ATTEMPT TO MAKE ANY ADJUSTMENT WHEN THE THROW ARM IS COCKED.**

1. Inspect the o-rings on the target rollers for wear every 6 - 12 months.
2. Inspect the Target brush for wear every 6 - 12 months.
3. Inspect the Throw Arm Brake Rubber and Flat Spring for wear or breakage every 6 - 12 months.
4. Inspect the throw arm approximately every 6 – 12 months.

If a groove forms on the face of the throw arm rubber, or the bottom edge is badly rounded, then the throw arm may be too high on the rim of the target.

To inspect the height of the throw arm you need to disconnect the main spring. First, move the arm to the front of the machine where the target leaves the machine. There should be 1/32" – 1/16" gap between the lip of the target and the bottom of the throw arm rubber. Take the measurement at the end of the throw arm.

After setting the arm to the correct height make sure that the throw arm scrapers clear the throw plate 360 degrees. Also check the clearance between the scraper and the doubles finger. If the throw arm is bent or the rubber is badly worn, send to PAT-TRAP, Inc. to be repaired.

5. Grease the throw arm shaft bearings every 1 ½ - 2 years. (see page 50 in manual)
6. If the Throw arm rubber surface appears glazed use a block of wood and 80 grit sandpaper to re-dress the surface – making sure to keep the sanding block square to the surface.
7. Grease Main Spring Crank Handle threads & washer yearly.



Maintenance Schedule

Item	Part Number	100,000 Targets	200,000 Targets	400,000 Targets	600,000 Targets	800,000 Targets	1,000,000 Targets
Target Brush	9041	•	•	•	•	•	•
O-Rings	9104	•	•	•	•	•	•
Main Spring (Uni-Bands)	9032		•	•	•	•	•
Throw Arm Rubber	SP120		•	•	•	•	•
Grease Main Shaft Bearings			15 yrs	•	•	•	•
8-Pin Relay	9208				•		
5W-20 Oil In Pump							•
Double Roller Wheel	9116	Monthly					

- - Inspect and/or Replace if worn or a performance issue.



## **PROCEDURE TO FLUSH HYDRAULIC OIL**

1. Please read completely before proceeding.
2. Remove the targets from the machine.
3. Turn the machine on, press the RIGHT oscillation button and oscillate all the way to the right until the cylinder bottoms-out.
4. For a Wobble machine, push the UP button until the cylinder bottoms out.
5. Leave the throw arm in the cocked position and turn the machine off.
6. Stand clear of the throw arm and disconnect the return-line hose (the male coupling).
7. A male coupling with three or four feet of hose now needs to be connected to the female coupling to direct the flow of oil into a pail.
8. The throw arm should still be in the cocked position. Turn the pump on and run until drained. Then, take the disconnected return-line hose and hold at full length above the pump and depress the ball valve to drain the oil from the hose. NOTE: You need to use the tip of your thumb or a screwdriver when depressing the ball so that the hose isn't blocked.
9. Leaving the throw arm in the cocked position, turn off the pump.
10. Fill the tank with new oil. USE 5W-20 motor oil. Add oil as needed after each of the following steps.
11. The next steps require having the pull cord release switch in your hand. First, turn the on/off/release switch ON.
12. Depress the pull cord button.
13. Turn the pump switch ON. The throw arm will fire and the turret will index.
14. Turn OFF the pump switch IMMEDIATELY when the throw arm has re-cocked.
15. Press the LEFT oscillation button and hold in while turning the pump switch ON. As soon as the cylinder bottoms-out, turn the pump OFF.
16. For the Wobble machine, Press the DOWN button and hold in while turning the pump switch ON. As soon as the cylinder bottoms-out, turn the pump OFF.
17. Re-connect the return-line hose. (See instruction 4)
18. The machine is now full of oil. Fill the tank to within one inch of the top.
19. Turn the machine on and move the wobble cylinder to center and move the oscillation cylinder to center. Resume normal operation.
20. 0W-20 motor oil can be used for colder temperatures)



## Timing of Pinion – PAT TRAP®

**WARNING: NEVER STAND IN FRONT OF TRAP MACHINE. THE TRAP MACHINE MUST BE TURNED OFF AND MAIN SPRING RELEASED PRIOR TO ENTERING THE TRAP HOUSE. NEVER ATTEMPT TO MAKE ANY ADJUSTMENTS WHEN THE THROW ARM IS IN THE COCKED POSITION.**

The following are the instructions for re-timing the turret pinion assembly on the G-Series Pat-Trap® Machine:

1. Unload the targets from the machine's turret and lift the turret off of the king pin. (Note: It is easier to remove the turret if two people lift up on opposite sides of the turret, i.e., 180° apart)

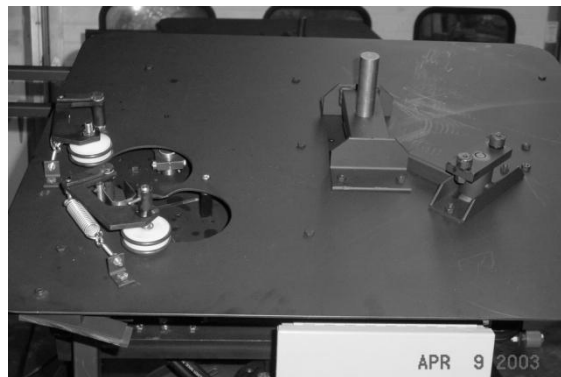

Picture 1.

2. Turn the pump on. Allow it to warm up for ten minutes or more if the temperature is cold. The Pump switch is the right-hand switch in Picture 2 below.



Picture 2.





3. Turn the machine on. When the throw arm comes forward to the throw arm brake and stops, it is in the cocked position. (See picture 3 below)

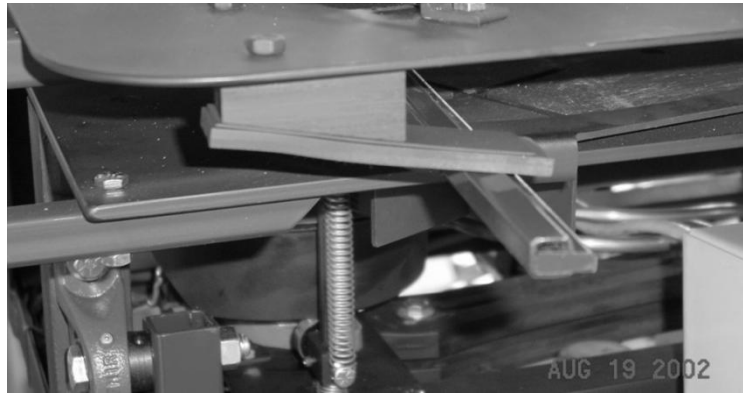

Picture 3.

4. Turn off the trap machine (Left Switch in Picture 2 above). Release the trap manually by standing clear of the throw arm and pushing the throw arm off the brake.
5. Compare the position of the pinion block on your trap machine with Diagram 1. The diagram represents the top view of the pinion block in relation to its base. The measurement given is taken from the corner "A" of the pinion block to the outside edge "B" of the pinion base (steel channel). The distance between points "A" and "B" is approximately 3/16" when correctly timed.

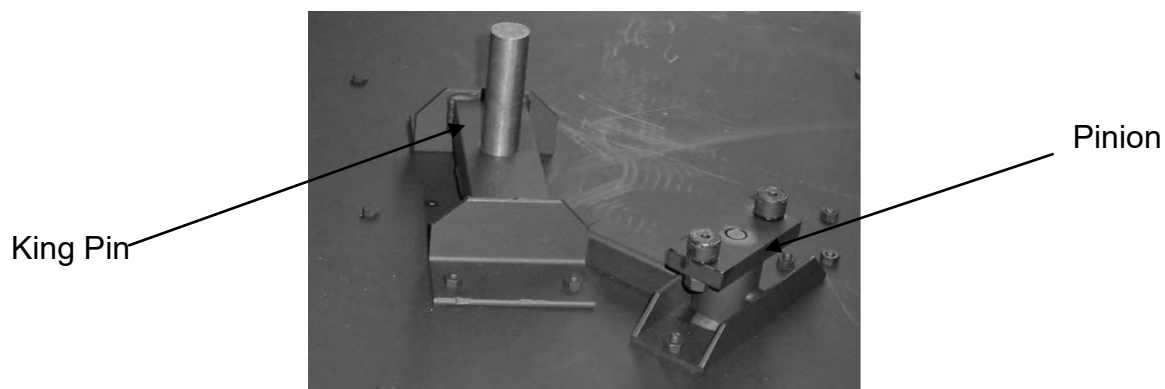

Picture 4.

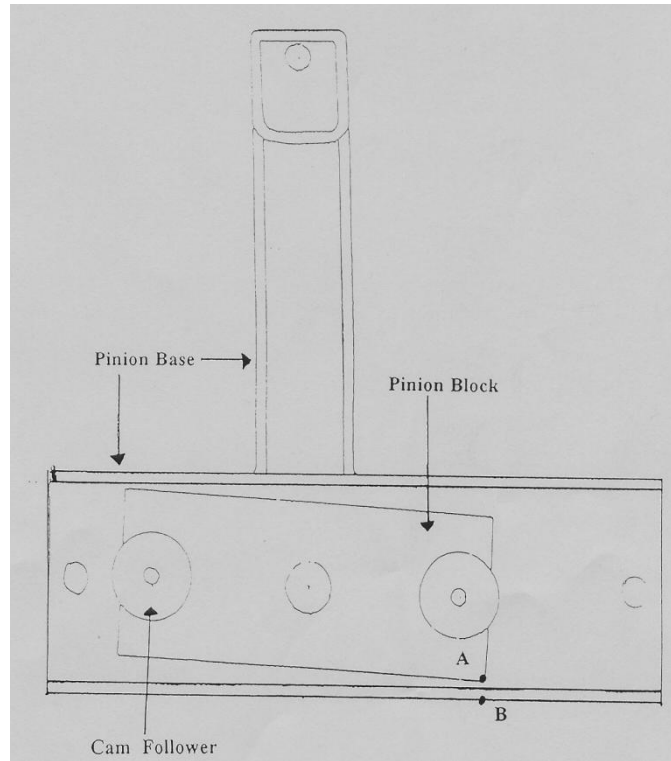

Diagram 1.

6. If the distance between points "A" and "B" is not close to the 3/16" spacing, then the timing can be corrected by disconnecting the drive chain to the pinion sprocket and rotating the pinion to the correct position and replacing the drive chain. See Picture 5.





Picture 5.

7. Note: The connecting link is located on the chain between the large sprocket and the small sprocket. If you can not see it, you will have to turn the trap machine on again and cycle it (repeat steps 3 and 4 above) until the connecting link comes around to the position required to remove it. Be sure to stay clear of the throw arm and that the machine is off and that the throw arm is released before working on the chain. Use a small screwdriver to remove the keeper bale for the connecting chain link. Once the chain is removed, position the pinion so that points "A" and "B" are at the 3/16" measurement, then reconnect the chain and the connecting link.



Picture 6.

8. Please call if you have any questions (603) 428-3396.

# "G" Series Trap & Wobble Trap Machine Power Control Box

Appendix V

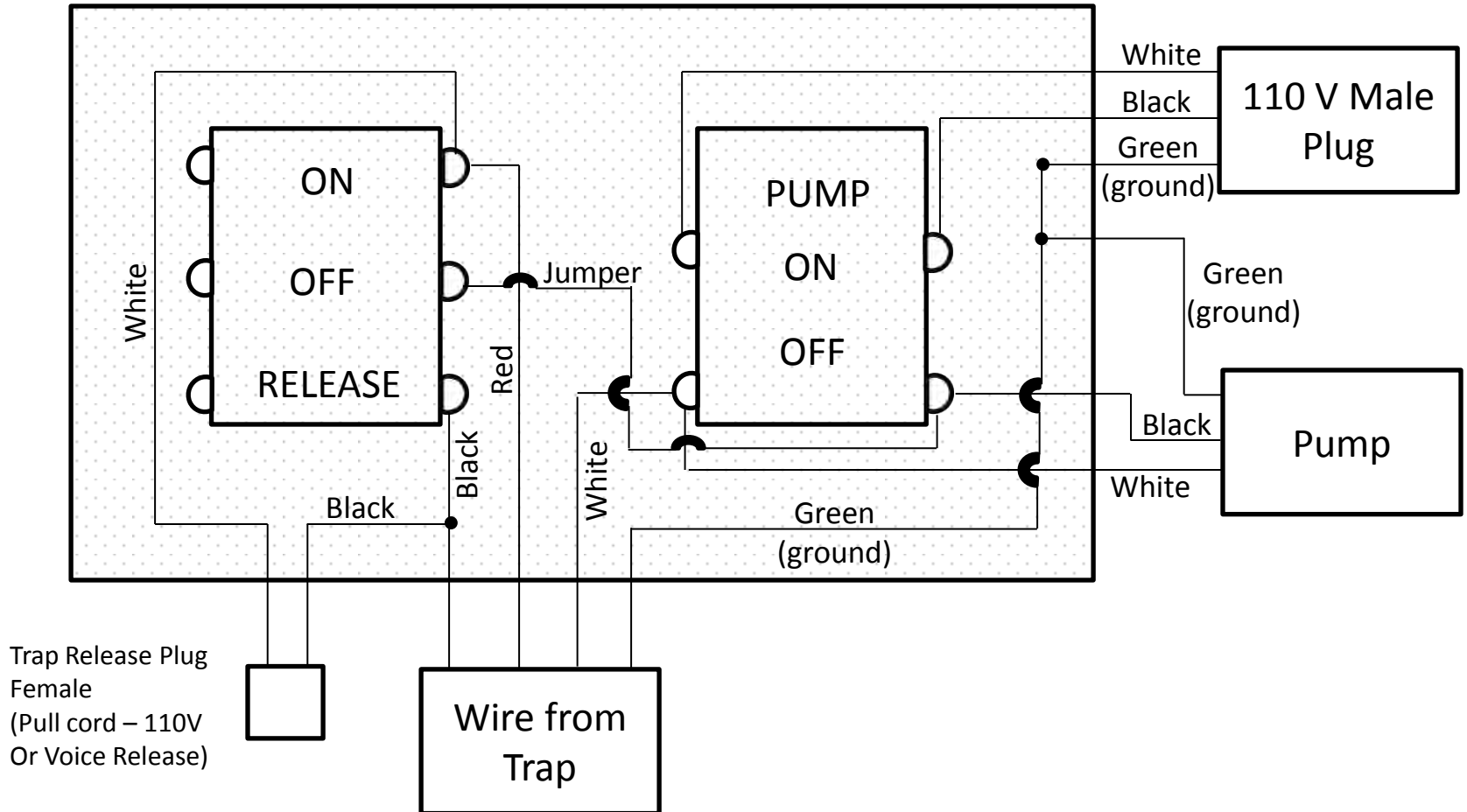

Trap Release Plug  
Female  
(Pull cord - 110V  
Or Voice Release)



## Drying Out a Pat-Trap® Machine After a Flood

1. **DO NOT TURN THE PAT-TRAP® MACHINE ON!** If you have turned the Pat-Trap® machine on before performing these steps you will need to buy a filter system from Pat-Trap, Inc. to remove water from the Pat-Trap® machine.
2. Disconnect the power to the trap house and the Pat-Trap® machine.
3. Open the gray electrical box located on the rear of the Pat-Trap® machine and remove the relays and the timer/interrupter from their respective bases.
4. Using a hair dryer, on a cool setting, dry out the relay bases and the inside of the electrical enclosure.
5. Remove the clear covers on relays and let the relays dry out.
6. Remove the rear cover on the clock motor of the timer/interrupter and let it dry out.
7. Pour out all of the oil in the reservoir of the hydraulic pump.
8. Pull out the drain plugs on the bottom of the farm duty electric motor attached to the hydraulic pump and let dry.
9. Remove all targets from the Pat-Trap® machine.
10. Use compressed air and towels to remove any excess dirt, debris and water on the exterior of the Pat-Trap® machine.
11. When dry, replace the covers on the relays and put them back into their appropriate relay bases.
12. When dry replace the rear cover on the timer/interrupter and replace into the relay base. ( Far right location inside the electrical enclosure)
13. When dry replace the drain plugs in electric motor.
14. Replace the oil in hydraulic pump reservoir with new 5W-20 motor oil to the appropriate full level. (2  $\frac{3}{4}$  quarts). Install water filter assembly.
15. Turn on the motor of the hydraulic pump on the Pat-Trap® machine and let it warm up for ten minutes (or longer if it is cold).
16. Turn on the Pat-Trap® machine and check to see that is it working. If problems occur call Pat-Trap, Inc. (603)428-3396.



## **TROUBLE SHOOTING**

NEVER STAND IN FRONT OF A TRAP MACHINE. THE TRAP MACHINE MUST BE TURNED OFF AND THE SPRING RELEASED BEFORE ENTERING THE TRAP HOUSE. NEVER ATTEMPT TO MAKE ANY ADJUSTMENT WHILE THE THROW ARM IS COCKED.

### OSCILLATION PROBLEM for Standard Pat-Trap & Wobble machine

Make certain that all switch wires and cables are properly connected. See plug – in terminal connections J4,J5,J6, and J7, and see Conn#1 and Conn#2 to make certain that the reed limit switch wires are securely connected. (Diagram # )

Stand to the right and rear of the machine near the Electrical Enclosure Box. Put the Auto/Manual switch into the manual position. Turn the machine on. If one or both directional buttons do not work then check the fuse(s). Next check Auto mode. If the machine does not oscillate after firing the throw arm or the oscillation or wobble cylinder is bottomed-out on the cylinder rod then follow the next procedures.

### AUTO MODE #11 & #12 (11A & 12A) SWITCHES

If a limit switch is stuck in either an Open or Closed state you can perform a continuity test with a meter. Disconnect the switch wires from their respective terminals and connect to your meter. Put a magnet beside the switch in question and see if the switch changes as it should.

If a limit switch intermittently fails, meaning that the cylinder bottoms out occasionally, then you will need to use trial and error to determine which switch is failing. Begin with the assumption that a switch is sticking in an open state; ie, if switch #12 sticks open then it will cause the machine to bottom out to the left (or down).

If the **#11 (11A) Switch** (N/O Right Angle Limit Reed Switch P/N 9222-G) is stuck “open” then the machine will travel all of the way right (up). This will cause the relief valve in the pump to engage and create a loud noise.

Switch to Manual Mode and use the manual push button to bring the machine back to center and replace the switch

If the **#12 (12A) Switch** (N/O Left Angle Limit Reed Switch P/N 9222-G) is stuck “open” then the machine will travel all of the way to the left (down) This will cause the relief valve in the pump to engage and create a loud noise.

Switch to Manual Mode and use the manual push button to bring the machine back to center and replace the switch.



If the **#11 (11A) Switch** (N/O Right Angle Limit Reed Switch P/N 9222-G) is stuck “closed” then the machine will travel all of the way to the left (all the way down). This will cause the relief valve in the pump to engage and create a loud noise.

Switch to Manual Mode and use the manual push button to bring the machine back to center and replace the switch.

If the **#12 (12A) Switch** (N/O Left Angle Limit Reed Switch P/N 9222-G) is stuck “closed” then the machine will travel all of the way to the right (all the way up). This will cause the relief valve in the pump to engage and create a loud noise.

Switch to Manual Mode and use the manual push button to bring the machine back to center and replace the switch.

#### AUTO/MANUAL SWITCH FOR STANDARD AND WOBBLE

The default mode is Auto. If the Auto/Manual Board is unplugged the machine will remain in the Auto mode: meaning that the machine should automatically oscillate left (down) and right (up) after firing the throw arm.

If the machine continues to oscillate or wobble automatically when the toggle switch is in manual mode then replace the Auto/Manual Board.

If the Left and/or Right Push Buttons do not work then try the Auto mode to see if the machine oscillates or wobbles in both directions. If the oscillation or wobble function is operational in Auto mode then the Soft Shift solenoid is good (PT9061) and the Main Board is good.

In this case change the Auto/Manual Switch Board.

#### SOFT SHIFT/SOLENOID VALVE (PT9061) and Main Board

In the case of a defective valve a short circuit might occur. A short will blow a fuse. Replace the correct fuse and follow the next steps.

In this event you will commonly find the oscillation or wobble cylinder bottomed-out on the rod.



Put the Auto/Manual switch into the Manual mode. If both left and right push buttons work then the valve is good. The cause of the bottoming-out of the cylinder could then be a bad limit reed switch, a bad cable connection or a stuck valve.

If the toggle switch is in Manual mode and you find that one directional button does not work and the other button causes a noise from the pump then the valve could be bad.

If both directional buttons do not work then check the fuses.

If a fuse is blown then replace it with proper fuse only. Unplug terminal J4 (oscillation ) or J6 (wobble). Turn the machine on and operate the Auto/Manual functions. If the fuse(s) does not blow then the Main Board is good.

Plug in the J4 or J6 terminal, one at a time, and turn on the machine. Operate the Auto/Manual functions. If the fuse(s) blows then replace the valve.

If the fuse(s) blows when either or both J4 and J6 terminals are unplugged when the machine is turned on then also unplug J2 and J3 and try again. If the fuse(s) blows then replace the Main Board.

Check that all cables and limit reed switch wires are properly plugged in or connected to their terminals.

#### A STUCK SOFT SHIFT VALVE FOR OSCILLATION OR WOBBLE (NON-ELECTRICAL PROBLEM)

In this case you will find the cylinder bottomed out to either the left or right or up and down. With the toggle switch in either Auto or Manual mode the pump will continue to strain (in relief mode). With the On/Off/Release switch in the off position and only the pump running you will hear the pump straining. In this case turn all power off and release the throw arm if cocked. Use a 1/8" diameter tool and push in firmly on both ends of the soft shift valve in question. The Manual shift push-rod should move in about 5/16". You will feel the resistance of a spring inside.

Turn the pump on to see if it runs normally. If it does then the valve is no longer stuck. Then try normal operation of the machine. If it sticks again then replace the valve.





THE THROW ARM WILL NOT COCK

Check **fuses**

Check the **#2 Micro Switch**

Check the **J1, J2 and J3 Cable Connections**

Check the **Hydraulic Solenoid Valve**

Check the **ON/OFF Release Switch** with an OHM meter with the power unplugged.

THROW ARM WILL NOT RELEASE WITH PULL CORD, VOICE RELEASE, OR THE ON/OFF/RELEASE SWITCH IN THE POWER BOX

Check fuses

Check the **#2 Switch**

Check cable connections J1, J2, J3.

Check the plug ends at the pull cord or voice release connection

Check the ON/OFF/RELEASE SWITCH with an OHM meter with the power unplugged.

THROW ARM DOES NOT STOP ON THE BRAKE (continually throws targets)

Disconnect the **Pull Cord** or **Voice Release System**

Check **Brake Assembly**

Check the **#2 Switch**: See "Cold Temperature Adjustment"

Check the **Hydraulic Solenoid Valve**

TARGETS BEGIN TO FALL SHORT OR THERE ARE AN UNUSUAL NUMBER OF TURNS ON THE CRANK HANDLE TO THROW A 50 YARD TARGET

Check for a broken **Uni-Band** (Main Spring)

Grease the **Main Shaft Bearing** with a low viscosity grease.



TARGETS ARE BEING THROWN MORE TO THE RIGHT

See **Target Brush** section

See **Throw Arm Maintenance** in **Maintenance** section

Check timing of the pinion

Check for a broken elevator spring

BROKEN TARGETS

Check the **Target Brush**

Check the **O-rings**

Check the **Elevator Springs**

Check the **Roller Plate Spring** tension

Check the **Throw Plate** surface for corrosion: Sand with 80 grit sand paper if needed.

Check **Pinion Timing**

If throwing Doubles, check the **Doubles Finger**: there will be a problem if the **Double finger** is bent upwards.

Check the **Singles Finger** and **Doubles Finger** measurement. See Diagram 50

# Solid State Cable Connections

3 ea 250V 3A Littelfuse cartridge.  
Spare fuses located inside enclosure cover.

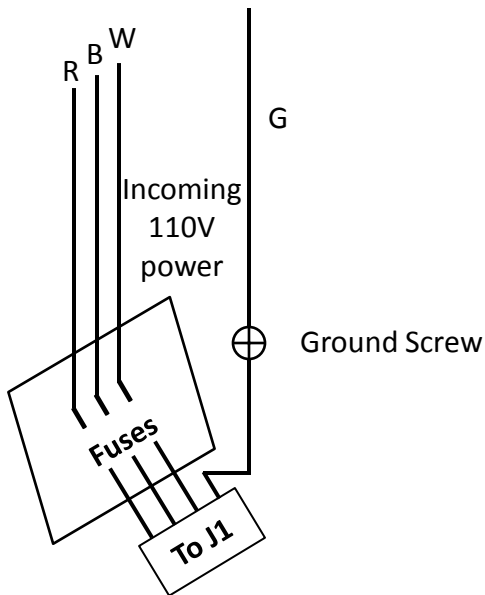

4 #06-32X3/8" socket head screws

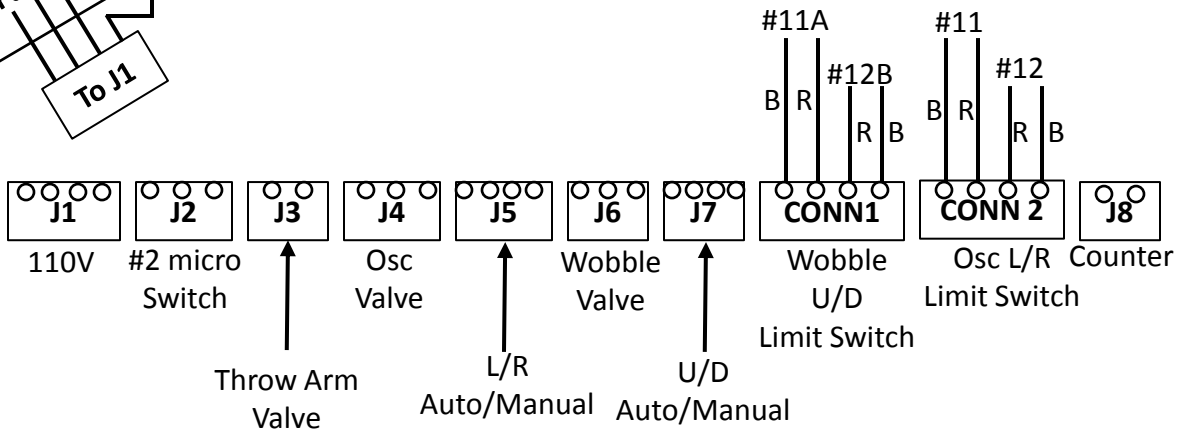

## Fasteners & Hardware

Main Board: 4- 6-32X3/8 T-handle hex wrench 7/64"

Auto/Manual Switch Board: 2-4-40X3/8 phillips head screw

Enclosure Cover: 7- 6-32x1/4 phillips head screws



# Index

## Adjustments

*Left/Right Angle Oscillation Limit Switches* ..... 9,23,55,56

*Wobble Up/Down Limit Switches* ..... 9,17,55,58

*Cold Weather* ..... 29

*Target Speed/Distance* ..... 19,20,43

*Singles/Doubles* ..... 12,13,15,17,18

*Release Time (Stopping the Throw Arm on the brake)* ..... 30

## Assembly

*Throw Arm Brake* ..... 29,32,46

*Throw Arm Cocking Pin* ..... 36

*Uni-Band (Main Spring)* ..... 39,42,43,44,45

## Brake

*Assembly of Throw Arm Brake/Maintenance* ..... 29,32,46

## Changing Uni-Bands on a Main Shaft Clutch System 43

## Clutch, Main Shaft

*Assembly/Installation of the Uni-Band (Main Spring) to the Main Shaft Clutch* ..... 39,42,43,44,45

*Changing a Pair of Uni-Bands on a Main Shaft Clutch System* 43,45

*Installation of Main Shaft Clutch* ..... 39,40,42

*Cocking Pin Assembly (Throw Arm)* ..... 36

*Cold Weather (Prevent Cycling of the Throw Arm)* ..... 29



## *Connection*

*Elevator Compression Spring* ..... 49

*Elevator Extension Spring* ..... 48

*Cycling Problem* ..... 29

*Dimensions and Weight* ..... 5

*Distance/Speed (Target)* ..... 19,20,21

## *Doubles*

*Setting Singles/Doubles Roller Plate System* 6,13,15,16,17,20,21,27

*Doubles Finger* ..... 16,35,37,38

*Doubles Finger, adjustment for doubles*..... 16

*Drying out a Pat-Trap* ..... Appendix VI

*Elevation Cog* ..... 15,22

*Elevator Spring Replacement*..... 48,49

*Fasteners/Hardware* ..... Appendix VIII

*Field Angle Adjustment (Left/Right Limit Switches)* .... 54

*Flush Hydraulic Fluid*..... Appendix II

*Fuse*..... 59

*Grease Bearings*..... Appendix I

*Hydraulic Cylinder For Wobbles* ..... 9,52,58,61,62,63,64



## **Installation**

<i>Elevator Compression Spring</i> .....	49
<i>Main Shaft Clutch</i> .....	39,440,42
<i>PAT-TRAP</i> .....	4
<i>Target Brush</i> .....	28
<i>Throw Arm</i> .....	34
<i>Throw Arm Brake</i> .....	33
<i>Uni-Band (Main Spring)</i> .....	45
<i>Uni-Band (Main Spring) to the Main Shaft Clutch</i> .....	45
<i>Doubles Finger</i> .....	37

<i>Loading the PAT-TRAP</i> .....	4,11
-----------------------------------	------

<i>Lubricate</i> .....	12,24
------------------------	-------

<i>Limit Switch (Left/Right)</i> .....	9,22,55,56
--	------------

## **Main Shaft Clutch**

<i>Assembly of Uni-Band to Main Shaft Clutch</i> .....	44
<i>Changing a Pair of Uni-Bands on a Main Shaft Clutch</i> .....	43
<i>Installation</i> .....	38,39,40,42

<i>Main Spring (uni-band), Disconnecting</i> .....	43
--	----

## **Maintenance**

<i>Flushing the Hydraulic Oil</i> .....	Appendix II
<i>Hydraulic Cylinder for the Wobble</i> .....	58
<i>Maintenance Schedule</i> .....	Appendix I
<i>Pump Motor</i> .....	61



**Maintenance cont.**

*Target Brush* ..... 28

*Throw Arm Brake*..... 32

*Throw Arm Cocking Pin* ..... 36

*Throw Arm Shaft Bearing* ..... 50

*Grease fittings* ..... 50

**Micro Switch #2**..... 8,9,30,31

**Mounting the Power Control Box** ..... 6

**ON/OFF, How to turn on and off** ..... 11

**Oil, How to Flush** ..... Appendix II

**Oil, How to turn on** ..... 6,11

**Oil, Type of** ..... 4

**Oscillation Cylinder, Replacement of** ..... 60

**Oscillation Soft Shift Valve, Wiring Guide** ..... 53

**On/Off/Release** ..... 7,8,10,11,13,14,15,16,29

**Pat-Trap**

*Dimensions and Weight* ..... 5

*How does it work*..... 8

*Installation* ..... 3

*Loading* ..... 11

*Singles* ..... 13

*Doubles*..... 15



*Pat-Trap cont.*

*Turn Off* ..... 11

*Turn On* ..... 11

*Wobble* ..... 17

*Pinion Assembly and Timing* ..... Appendix III

*Positioning of Roller Plates* ..... 25

*Power Control Box* ..... 6

*Connecting*..... 7

*Mounting*..... 2,3,6

*Power Source Connection* ..... 7

*Pull Cord (Switch #1)* ..... 7

*Pump Motor*..... 4

*Flushing Hydraulic Fluid* ..... 1

*Pump Switch* ..... 6,10

*Reed Switch*

*How it works* .....8,9,10

*Hydraulic Cylinder for Wobble* ..... 9,11

*Wiring Guide#11(A) and #12(A) Switches* ..... 56

*Removal/Replacement*

*Hydraulic Valve* ..... 53

*Elevator Spring* .....48,49

*Field Angle/Limit Switch*.....54,55





*Removal/Replacement cont.*

*Oscillation Cylinder* ..... 56

*Wobble Cylinder* ..... 58

*Positioning of the Roller Plate* ..... 25

*Throw Arm* ..... 33

*Turret* ..... 5

**Relay #2 – L/R Oscillation** ..... 9,56,57

**Interrupter** ..... 9,10,17

**Setting Single/Doubles** ..... 13,15,16,17,18,20,21,22

**Shifting the Target Field** ..... 24

**Singles** ..... 13

**Single & Doubles Finger** ..... 37

**Soft Shift Valve** ..... 51,52,53

**Speed/Distance** ..... 19,20,21

**Springs**

*Disconnecting the Uni-Band (Main Spring)* ..... 34

*Elevator Compress Spring* ..... 48

*Elevator Extension Spring* ..... 25,48

*Uni-band (Main Spring)* ..... 1,6,11,13,15,16,19,20,21,22

**Straightaway Targets** ..... 29,30



## **Switches**

#2..... 8,9,10,30,31  
#11(A) & #12(A) ..... 9,10,23,55  
Switch ID ..... 10

*(Two) 2-Hole Targets/(Three)3-Hole Targets ..... 23,24,56*

**Target Bush Maintenance ..... 28**

## **Targets**

*Angle Adjustment ..... 9,23*  
*Height Adjustment ..... 18*  
*Setting Speed and Distance ..... 19,20*  
*Target Field, shifting ..... 29*

**Temperature/Release Time ..... 28**

## **Throw Arm**

*Brake Assembly ..... 29,32*  
*Brake Installation ..... 32*  
*Cocking Pin Assembly ..... 36*  
*Installation ..... 34*  
*Removal of..... 33*  
*Shaft Bearing ..... 48*  
*Stopping the Throw Arm on the Brake ..... 29,32*  
*Throw Arm/Turret Valve Wiring Guide ..... 49, 52*

**Trouble Shooting ..... Appendix VII**

**Turret, Removal/Replacement..... 6**



*Uni-Band* ..... *See Main Spring*

**Valves**

*Soft Shift, Oscillation* ..... 52, 53

*Throw Arm/Turret* ..... 54, 56

**Wiring Guide**

*Hydraulic Cylinder for Wobble* ..... 51

*Oscillation Soft Shift Valve* ..... 51

*Pat-Trap & Wobble* ..... *Appendix V*

*Switches #11(A) & #12(A)* ..... 55

*Throw Arm/Turret Valve* ..... 52

**Wobble**

*Change over to* ..... 17, 18

*Height Adjustment for Single/Doubles* ..... 17, 18

*Hydraulic Cylinder* ..... 55, 58

*UP/DOWN Limit Switch* ..... 55, 58

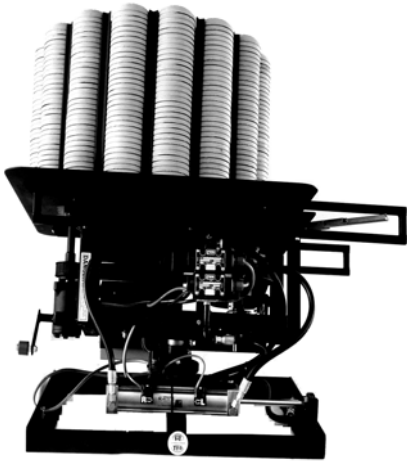

U.S. PATENTS(S): 5249563, 6176229

# Pat-Trap®

---

## AUTOMATIC SINGLE/DOUBLES

Manufactured by:

Pat-Trap, Inc  
632 Western Ave  
Henniker, NH. 03242

Telephone: 603-428-3396

Web Site: [www.pattrap.com](http://www.pattrap.com) Email: [pattrap@tds.net](mailto:pattrap@tds.net)

Pat-Trap, Inc. warrants the Pat-Trap® Automatic Single/Doubles machine against defects in material or workmanship for a period of one year from date of original purchase; and agrees to repair **or**, at our option, replace any defective unit without charge.

**IMPORTANT:** This warranty does not cover transportation cost. Nor does it cover any damage resulting from accident, misuse or abuse, and any modifications or alterations including attaching the unit to other than the recommended receptacle or voltage.

**NO RESPONSIBILITY IS ASSUMED FOR ANY SPECIAL, INCIDENTAL OR CONSEQUENTIAL DAMAGES.**

**Millions and Millions of Targets Served!**